



DISHWASHER

SERVICE MANUAL

NOTE

BEFORE SERVICING THE UNIT, PLEASE READ THIS MANUAL CAREFULLY FOR SAFETY AND CORRECT SERVICES.

MODEL : LDF6810WW / LDF6810BB / LDF6810ST
LDF7810WW / LDF7810BB / LDF7810ST
LDF7811WW / LDF7811BB / LDF7811ST
LDS5811WW / LDS5811BB / LDS5811ST

CONTENTS

1. CAUTION.....	4
2. SPECIFICATIONS	5
3. WIRING DIAGRAM.....	6
4. FEATURES & TECHNICAL EXPLANATION	7
5. PARTS NAME	16
6. PROGRAM CHART	19
7. HOW TO DISASSEMBLE	21
8. TROUBLE SHOOTING METHODS.....	30
A. TROUBLE SHOOTING ACCORDING TO DISPLAYED ERROR MESSAGE	30
B. TROUBLE DIAGNOSES AND REPAIR BY SYMPTOM.....	32
9. INSTALLATION INSTRUCTION	36
10. EXPLODED VIEW	43
11. REPLACEMENT PART LIST	52

CAUTION !

- DISCONNECT POWER CORD BEFORE SERVICING
- RECONNECT ALL GROUNDING DEVICES

IMPORTANT SAFETY NOTICE !

This service information is intended for individuals possessing adequate backgrounds of electrical, electronic and mechanical experience.

Any attempt to repair this appliance may result in personal injury and property damage.

The manufacturer or seller can not be responsible for the interpretation of this information, nor can it assume any liability in connection with its use.

2. SPECIFICATION

ITEM	SPECIFICATION
Rated Voltage / Frequency	AC 120V/60Hz
Installation	Built-In
Place Settings	16
Product Dimension(in)	23 7/8" x 25" x 33 7/8"
Product Weight(lbs)	7811/7810 series : 115lbs, 5811/6810 series : 110lbs
Door Color	White, Black, Stainless
Tub Material	Stainless Steel
Control	Electronic
Rated Power(Watt)	1,350
Heater Power(Watt)	1,200
Programs	7811/7810 series : 6, 6810 series : 5
Upper Rack Position	7811/7810 series : Adjustable, 5811/6810 series : manual
Lower Rack	50% Fold down
Water Consumption (ℓ)	21-30 (Normal)
Power Consumption(kWh/year)	352~370
Operating Time (min)	101-135 (Normal)
Fan Dry System	Yes
Delay Start Function	Yes
Auto-Off Power Switch	Yes
Process Monitor	Yes
Wash Level	5
Racks	Nylon Coating
Operating Water Pressure (Bar)	20-120 (140-830kPa)

3. WIRING DIAGRAM

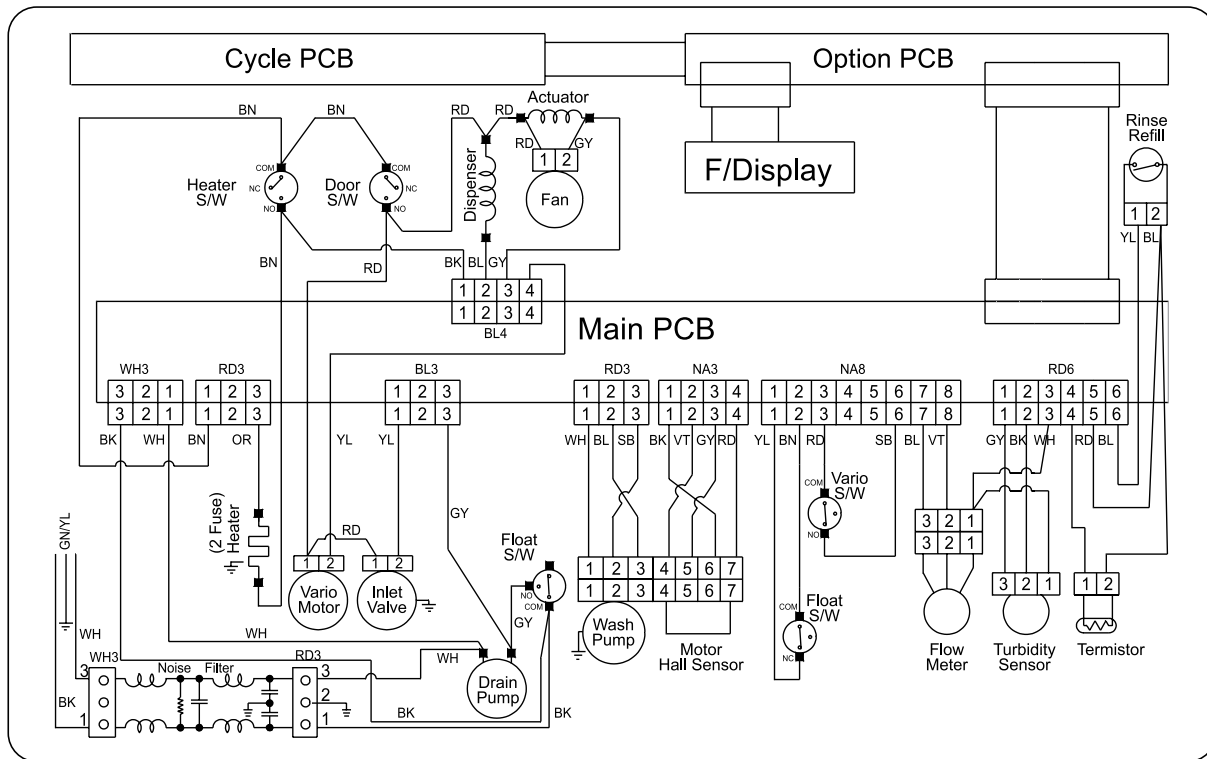

4. FEATURES & TECHNICAL EXPLANATION

4-1. Product Features

■ Ultra Big Capacity

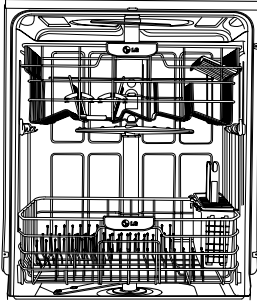

If you raise the Upper Rack, you can load large dishes in the Lower Rack. (Max. 14 in.)

The tall tub provides large dishes loading as well as large capacity.

LG dishwashers let you load oversized items in the Lower and Upper Rack.

■ Slim Direct Inverter Motor

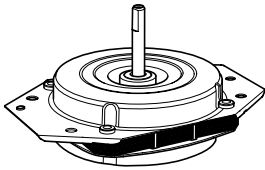

Newly introduced Slim Direct Inverter motor is inverter-controlled. Speed is controlled based on program selection. It also offers high energy efficiency to minimize energy loss.

■ Hybrid Drying System

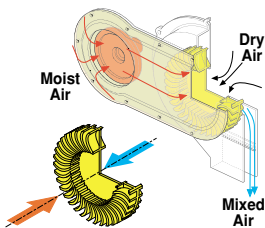

This is one of the best performance solutions for drying dishes because it minimizes venting humid air to the outside of the dishwasher. In addition, this system ensures better drying results compared to the condensing drying system.

■ Vario Spray System

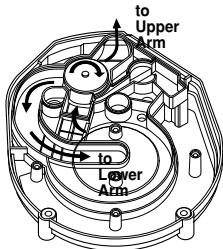

Because of alternating water spray between the Upper and Lower Rack, the water pressure allows superior performance and reduced consumption of water and electricity.

■ Self Cleaning Filter

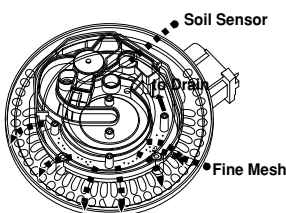

For best wash results, the self-cleaning filter system continuously cleans the water as it circulates. Your LG dishwasher has a self-cleaning filter that grinds food into small particles before it goes down the drain.

4-2. Display Panel

4-2-1. LDF 7811/7810 Series

■ Control panel may vary on some models.

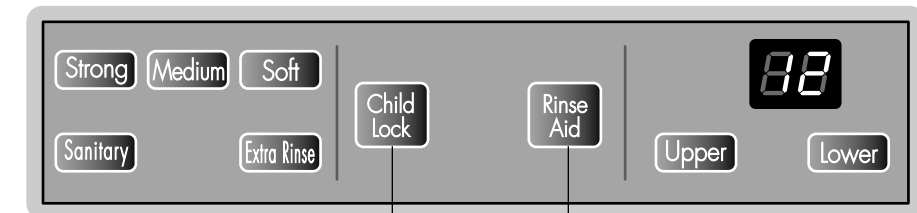

INDICATOR

- Child lock: Lamp will turn on when **Child Lock** setting is on.
- Rinse Aid: Refill with Rinse aid when Lamp turns on.

PROGRAM

- Press the program that corresponds to your desired wash cycle.

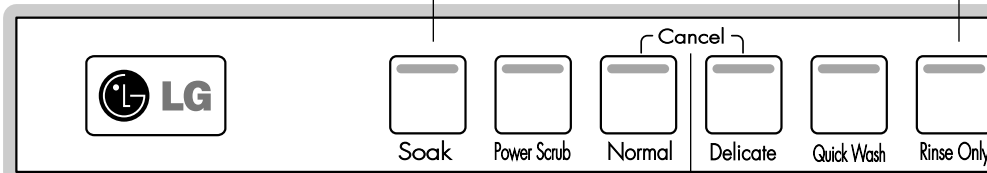

Soak

This program is for very heavily soiled loads including pots, pans and casserole dishes which may have dry food residue.

Power Scrub

This program is for very heavily soiled loads

Normal

This program is for normally soiled everyday loads.

Delicate

This program is for washing delicate items like glasses.

Quick Wash

This program is for that quick wash of lightly soiled recently used dishes and cutlery.

Rinse Only

This program is for very lightly soiled loads.

CANCEL

- To cancel a running program, open the door, then press and hold the **Normal** and **Delicate** buttons for 3 seconds.

SPRAY (INTENSITY)

- Repeated pressing of the Spray button will select **Strong, Medium** or **Soft**.

DELAY START

- If you want to delay the start of a selected program, press the **Delay Start** button.
- Each press of **Delay Start** will delay the start of the cycle by one hour.
- The delay start time can be adjusted from 1 to 24 hours in one-hour increment.

POWER

- For operating, press this button first for power on.
- After operating, the power automatically switches off for safety and economy.
- In case of an unusual Power surge or disturbance, the power may be automatically turned off for safety.

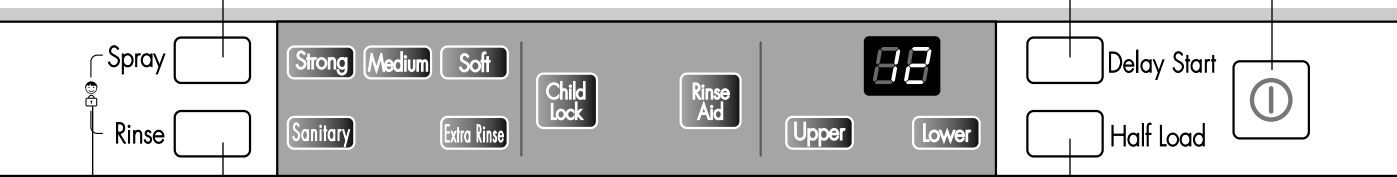

CHILD LOCK

- Lock the control buttons to prevent the settings from being changed.
- To lock/unlock, press **Spray** and **Rinse** buttons simultaneously for 3 seconds with door open.

SANITARY/ EXTRA RINSE

- Repeated pressing of the Rinse button will select **Sanitary, Extra Rinse** or both.
- If you select the **Sanitary** function, the temperature of Heating Rinse can reach 161°F (72°C).
- When you select **Extra Rinse**, an additional rinse cycle is added.

HALF LOAD

- In case of a small load, use the upper or lower rack only to save energy.
- Each press of the **Half Load** button cycles between upper rack only and lower rack only.
- If you don't press **Half Load**, the dishwasher runs normally, i.e. operation of upper and lower spray arm alternating periodically.

4-2-2. LDF 5811 Series

SPRAY (INTENSITY)

- Repeated pressing of the Spray button will select **Strong, Medium** or **Soft**.

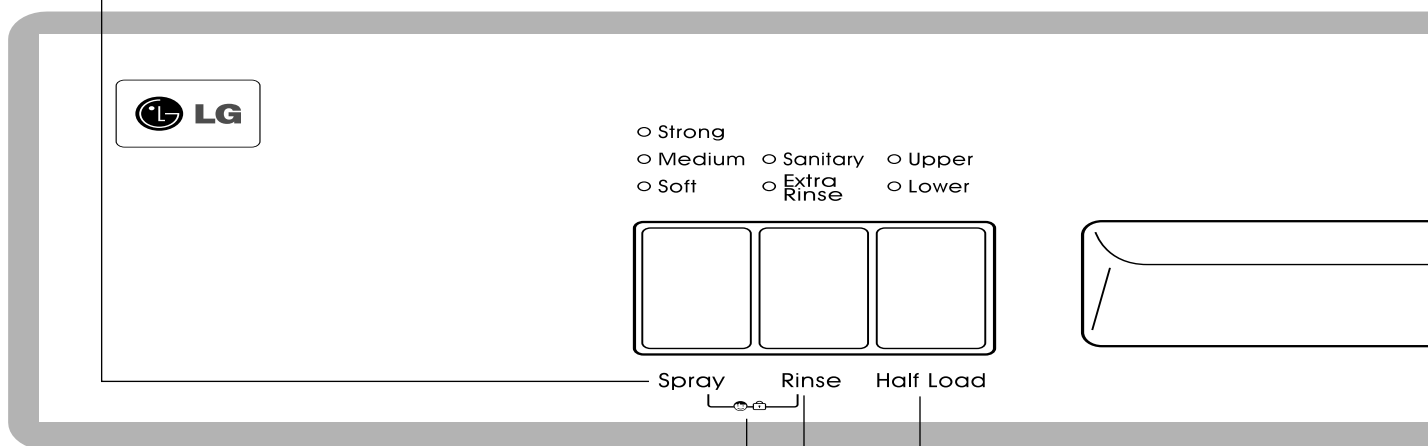

CHILD LOCK

- Lock the control buttons to prevent the settings from being changed.
- To lock/unlock, press **Spray** and **Rinse** buttons simultaneously for 3 seconds.

SANITARY/ EXTRA RINSE

- Repeated pressing of the Rinse button will select **Sanitary, Extra Rinse** or both.
- If you select the **Sanitary** function, the temperature of Heating Rinse can reach 161 °F (72 °C).
- When you select **Extra Rinse**, an additional rinse cycle is added.

HALF LOAD

- In case of a small load, use the upper or lower rack only to save energy.
- Each press of the **Half Load** button cycles between upper rack only and lower rack only.
- If you don't press **Half Load**, the dishwasher runs normally, i.e. operation of upper and lower spray arm alternating periodically.

INDICATOR

- Child lock: Lamp will turn on when **Child Lock** setting is on.
- Rinse Aid: Refill with Rinse aid when Lamp turns on.

PROCESSING INDICATOR

- Current program phase is indicated.

TIME LEFT

- Before starting, the display window shows the running time of the selected program.
- After starting, the display window shows the remaining time.
- If the dishwasher has a trouble, the trouble type is displayed.

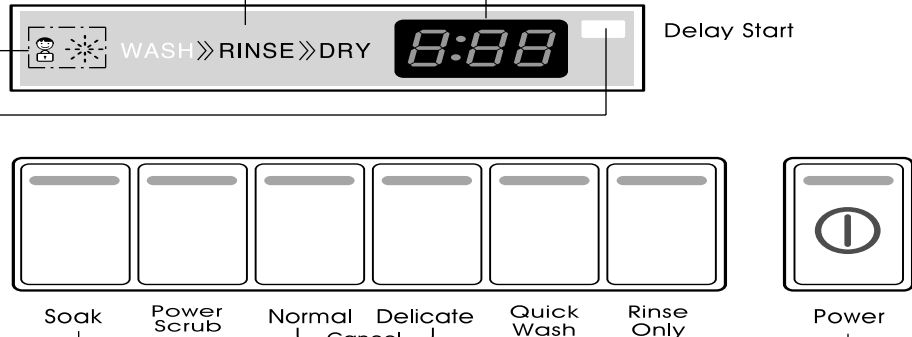

DELAY START

- If you want to delay the start of a selected program, press the **Delay Start** button.
- Each press of **Delay Start** will delay the start of the cycle by one hour.
- The delay start time can be adjusted from 1 to 12 hours in one-hour increment.

CANCEL

- To cancel a running program, press and hold the **Normal** and **Delicate** buttons for 3 seconds.

PROGRAM

- Press the program that corresponds to your desired wash cycle.

POWER

- For operating, press this button first for power on.
- After operating, the power automatically switches off for safety and economy.
- In case of an unusual Power surge or disturbance, the power may be automatically turned off for safety.

4-2-3. LDF 6810 Series

■ Control panel may vary on some models.

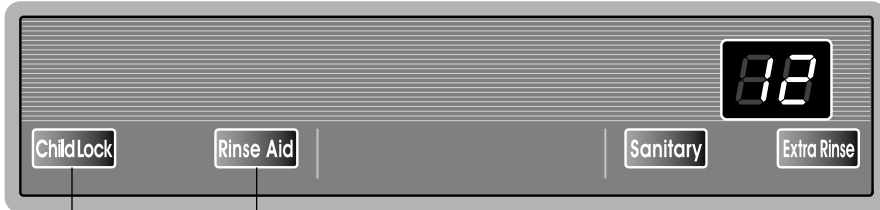

INDICATOR

- Child lock: Lamp will turn on when **Child Lock** setting is on.
- Rinse Aid: Refill with Rinse aid when Lamp turns on.

PROGRAM

- Press the program that corresponds to your desired wash cycle.

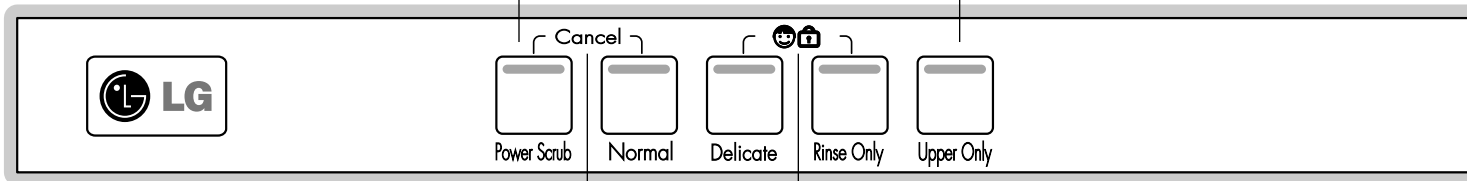

- Power Scrub** This program is for very heavily soiled loads
- Normal** This program is for normally soiled everyday loads.
- Delicate** This program is for washing delicate items like glasses.
- Rinse Only** This program is for very lightly soiled loads.
- Upper Only** This program is to wash some items loaded on the upper rack.

CANCEL

- To cancel a running program, open the door, then press and hold the **Power Scrub** and **Normal** buttons for 3 seconds.

DELAY START

- If you want to delay the start of a selected program, press the **Delay Start** button.
- Each press of **Delay Start** will delay the start of the cycle by one hour.
- The delay start time can be adjusted from 1 to 12 hours in one-hour increment.

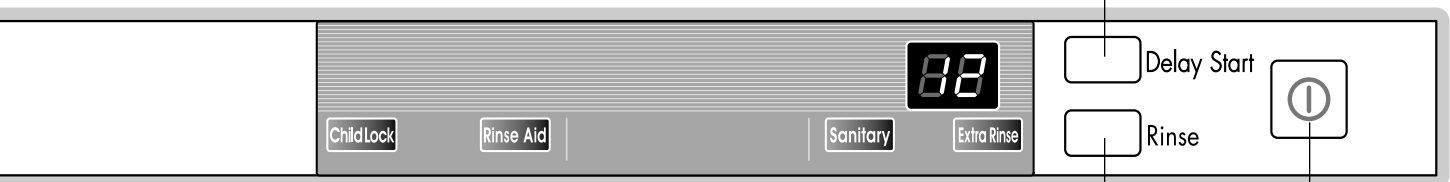

CHILD LOCK

- Lock the control buttons to prevent the settings from being changed.
- To lock/unlock, press **Delicate** and **Rinse Only** buttons simultaneously for 3 seconds with door open.

SANITARY/ EXTRA RINSE

- Repeated pressing of the Rinse button will select **Sanitary, Extra Rinse** or both.
- If you select the **Sanitary** function, the temperature of Heating Rinse can reach 161 °F (72 °C).
- When you select **Extra Rinse**, an additional rinse cycle is added.

POWER

- For operating, press this button first for power on.
- After operating, the power automatically switches off for safety and economy.
- In case of an unusual Power surge or disturbance, the power may be automatically turned off for safety.

4-3. TEST MODE

4-3-1. LDF 7811/7810 LDS 5811 Series

CHECK PROGRAM

BUTTON	The number of pushing button	Top Display	Front Display	Load and Checking points		Door open/closed
Rinse + Time Delay + POWER S/W	1 TIME	3H/U2	n : 3H/U:02	All LEDs are lighting		Both
Soak	1 TIME	11	1 : 11	All LEDs are lighting		Both
Power Scrub	1 TIME	22	2 : 22	All LEDs are lighting		Both
Normal	1 TIME	33	3 : 33	All LEDs are lighting		Both
Delicate	1 TIME	44	4 : 44	All LEDs are lighting		Both
Quick Wash	1 TIME	55	5 : 55	All LEDs are lighting		Both
Rinse Only	1 TIME	66	6 : 66	All LEDs are lighting		Both
Supply	1 TIME	77	7 : 77	Strong/Medium/Soft		Both
Rinse	1 TIME	88	8 : 88	Sanitary-Extra Rinse		Both
Half Load	1 TIME	99	9 : 99	Upper-Lower		Both
Time Delay	1 TIME	31	^① Soil Level	Soil Sensor	Delay Start	Both
	2 TIME	32	n : 02	Wash Pump	Child Lock + Rinse Aid	Closed
	3 TIME	33	n : 03	Drain Pump	Wash	Closed
	4 TIME	34	^② Frequency	Inlet Valve	Rinse	Both
	5 TIME	35	n : 05	Dispenser	Dry	Closed
	6 TIME	36	n : 06	Heater (for 10 sec)	Wash-Rinse-Dry	Closed
	7 TIME	37	n : 07	Fan	Strong-Soft	Closed
	8 TIME	38	n : 08		Sanitary-Extra	
	9 TIME	39	Temp. (°C)	Thermistor	Upper-Lower	Both
	10 TIME	3A	n : 0A	Lower Nozzle (VARIO)	Soak-Normal	Closed
	11 TIME	3b	n : 0b	Upper Nozzle (VARIO)	Delicate-Rinse Only	Closed
	12 TIME	3c	n : 0c	Wash-Drain-Water Supply	Rinse Aid	Closed
	13 TIME			Auto-Off		Closed

① Normal Water Level : 315

② Pure Water : more than 229

※ Supply water before operating the Test Mode.

4-3-2. LDF 6810 Series

CHECK PROGRAM

BUTTON	The number of pushing button	Top Display	Load and Checking points		Door open/closed
Upper Only + Time Delay + POWER	1 TIME	3H/U2	All LEDs are lighting		Both
Power Scrub	1 TIME	11	All LEDs are lighting		Both
Normal	1 TIME	22	All LEDs are lighting		Both
Delicate	1 TIME	33	All LEDs are lighting		Both
Rinse Only	1 TIME	44	All LEDs are lighting		Both
Upper Only	1 TIME	55	All LEDs are lighting		Both
					Both
Rinse	1 TIME	66	All LEDs are lighting		Both
					Both
Time Delay	1 TIME	31			Both
	2 TIME	32	Wash Pump		Closed
	3 TIME	33	Drain Pump		Both
	4 TIME	34	Inlet Valve		Closed
	5 TIME	35	Dispenser		Closed
	6 TIME	36	Heater (for 10 sec)		Closed
	7 TIME	37	Fan		Closed
	8 TIME	38		Child Lock + Rinse Aid	
	9 TIME	39	Thermistor	Sanitary-Extra	Both
	10 TIME	3A	Lower Nozzle (VARIO)	Power Scrub + Normal + Delicate	Closed
	11 TIME	3b	Upper Nozzle (VARIO)	Rinse Only + Upper Only	Closed
	12 TIME	3c	Wash-Drain-Water Supply	Rinse Aid	Closed
	13 TIME		Auto-Off		Closed

① Normal Water Level : 295

5. PARTS NAME

5-1. LDF 7811/7810 Series

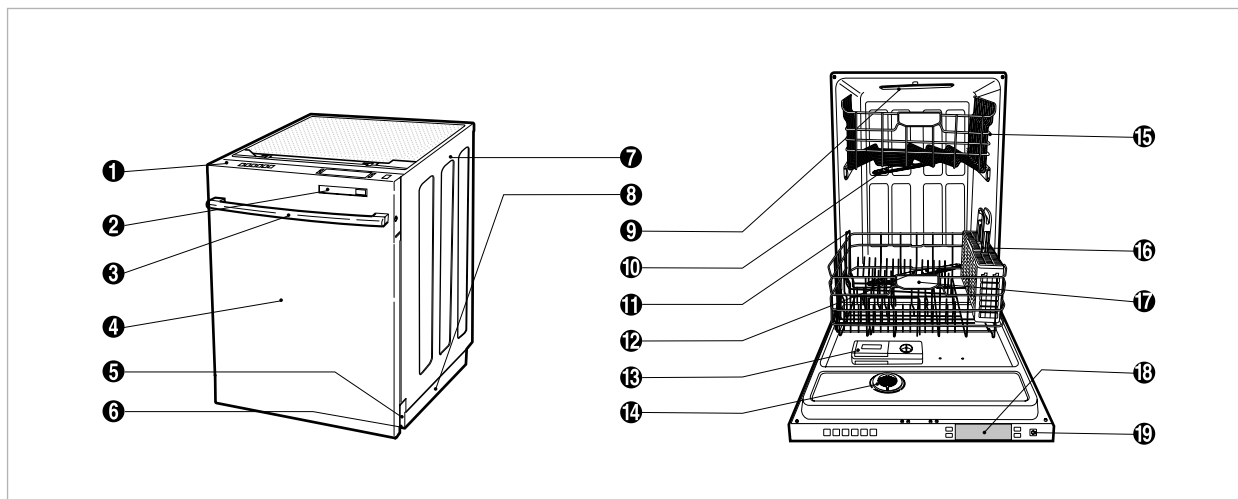

- | | |
|-------------------|------------------------------------|
| ❶ Control Panel | ❶❶ Removable Tines |
| ❷ Front Display | ❶❷ Lower Spray Arm |
| ❸ Door Handle | ❶❸ Detergent & Rinse Aid Dispenser |
| ❹ Front Cover | ❶❹ Vapor Vent Cover |
| ❺ Lower Cover | ❶❺ Upper Rack |
| ❻ Leveling Foot | ❶❻ Cutlery Basket |
| ❼ Side Cabinet | ❶❼ Lower Rack |
| ❽ Base | ❶❽ Top Display |
| ❾ Top Spray Arm | ❶❾ Power Button |
| ❿ Upper Spray Arm | |

Accessories

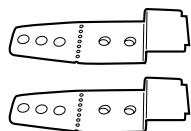

INSTALL BRACKET



WOOD SCREW

※ The appearance and specifications may be varied without notice according to localities.

5-2. LDF 5811 Series

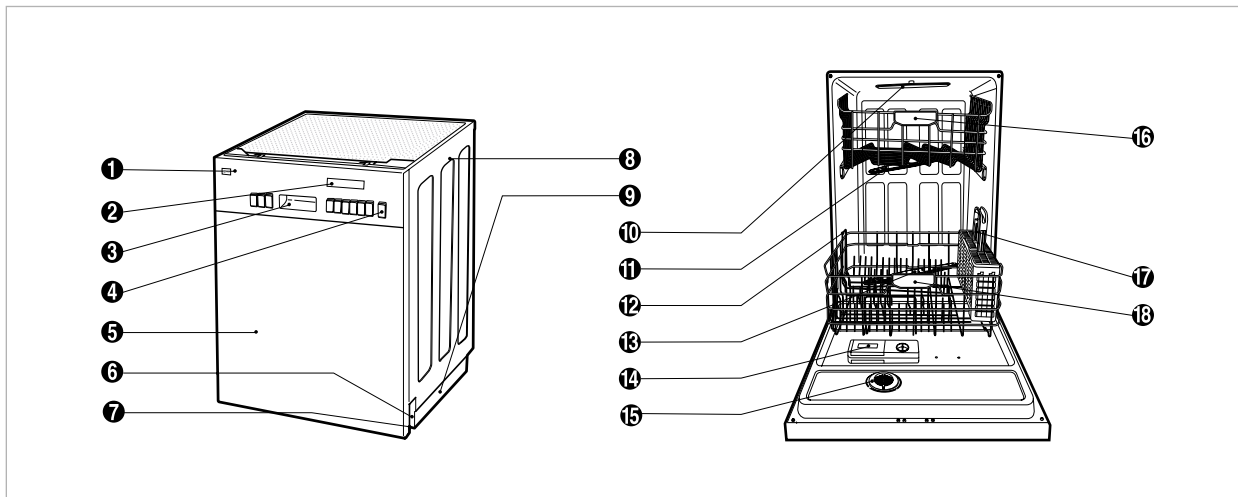

- ❶ Control Panel
- ❷ Front Display
- ❸ Door Handle
- ❹ Power Button
- ❺ Front Cover
- ❻ Lower Cover
- ❼ Leveling Foot
- ❽ Side Cabinet
- ❾ Base

- ❿ Top Spray Arm
- ⓫ Upper Spray Arm
- ⓬ Removable Tines
- ⓭ Lower Spray Arm
- ⓮ Detergent & Rinse Aid Dispenser
- ⓯ Vapor Vent Cover
- ⓰ Upper Rack
- ⓱ Cutlery Basket
- ⓲ Lower Rack

Accessories

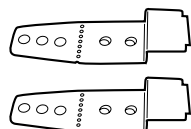

INSTALL BRACKET



WOOD SCREW

※ The appearance and specifications may be varied without notice according to localities.

5-3. LDF 6810 Series

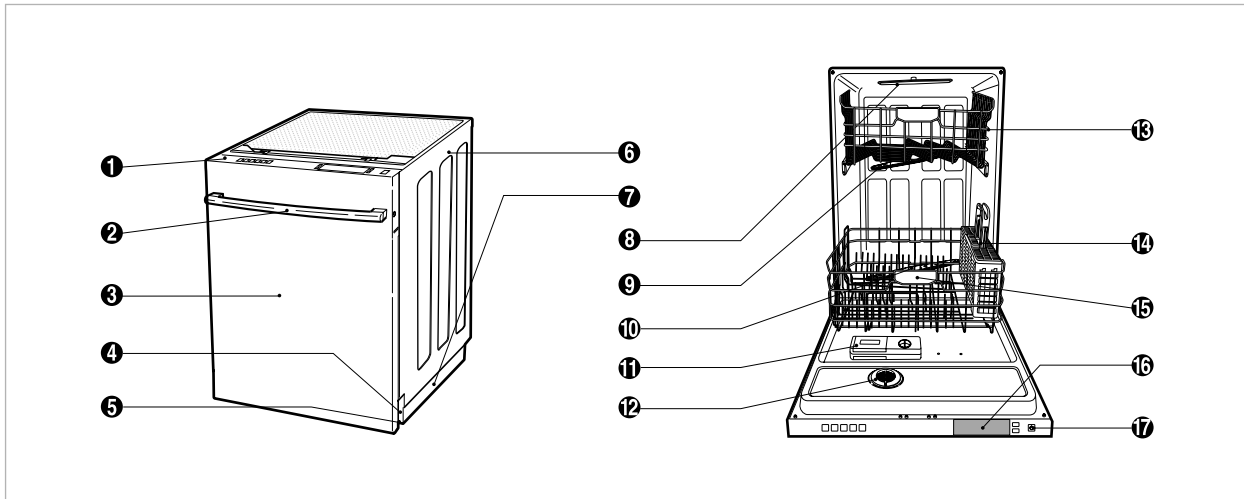

- | | |
|-------------------|-----------------------------------|
| ① Control Panel | ⑩ Lower Spray Arm |
| ② Door Handle | ⑪ Detergent & Rinse Aid Dispenser |
| ③ Front Cover | ⑫ Vapor Vent Cover |
| ④ Lower Cover | ⑬ Upper Rack |
| ⑤ Leveling Foot | ⑭ Cutlery Basket |
| ⑥ Side Cabinet | ⑮ Lower Rack |
| ⑦ Base | ⑯ Top Display |
| ⑧ Top Spray Arm | ⑰ Power Button |
| ⑨ Upper Spray Arm | |

Accessories

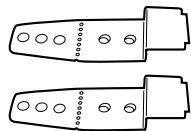

INSTALL BRACKET



WOOD SCREW

※ The appearance and specifications may be varied without notice according to localities.

6. PROGRAM CHART(SCHEMATIC DIAGRAM)

6-1. LDF 7811/7810 LDS 5811 Series

Program chart

Program	Wash										Rinse										Dry					
	Pre Wash 1		Pre Wash 2				Pre Wash 3				Main Wash				Rinse 1				Rinse 2				Heating Rinse		Dry	
	Drain A	Water Supply	Drain B	Water Supply	Drain B	Water Supply	Drain B	Water Supply	Drain B	Water Supply	Drain B	Water Supply	Drain B	Water Supply	Drain B	Water Supply	Drain B	Water Supply	Drain C	Water Supply	Drain C	Water Supply	Drain D	Water Supply		
Soak	26	49																								
Power Scrub		18																								
NORMAL		10																								
Delicate		10																								
Quick																										
Rinse Only																										
W/Motor																										
Drain Pump																										
Inlet Valve																										
Heater																										
Vario Motor																										
Fan Motor																										
Dispenser																										
Thermal Act																										
Auto Off SW																										

7. HOW TO DISASSEMBLE

BEFORE DISASSEMBLING THE DISHWASHER ;

- 1) Remove the cord from electric outlet to avoid electric shock.
- 2) Close the Water Tap (faucet).
- 3) Remove all dishes and items in the dishwasher.
- 4) Remove the Lower Rack and the Upper Rack.
- 5) Remove the inlet hose and drain hose connection to avoid the hose damages.
- 6) Prepare some towels to avoid floor wet by the water left in the dishwasher.

7-1. FULL DISASSEMBLE

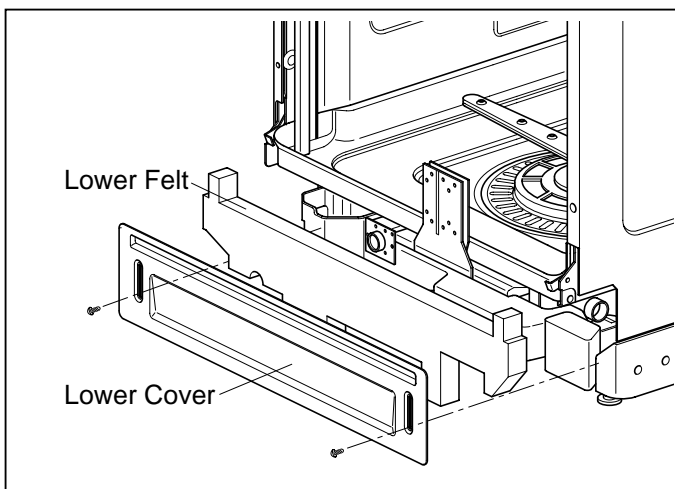

1. Lower Cover and Lower Felt

- 1) Remove the front 2 screws.
- 2) Pull the Felt.
- 3) Remove the Inlet Hose and Power Supply Cable.

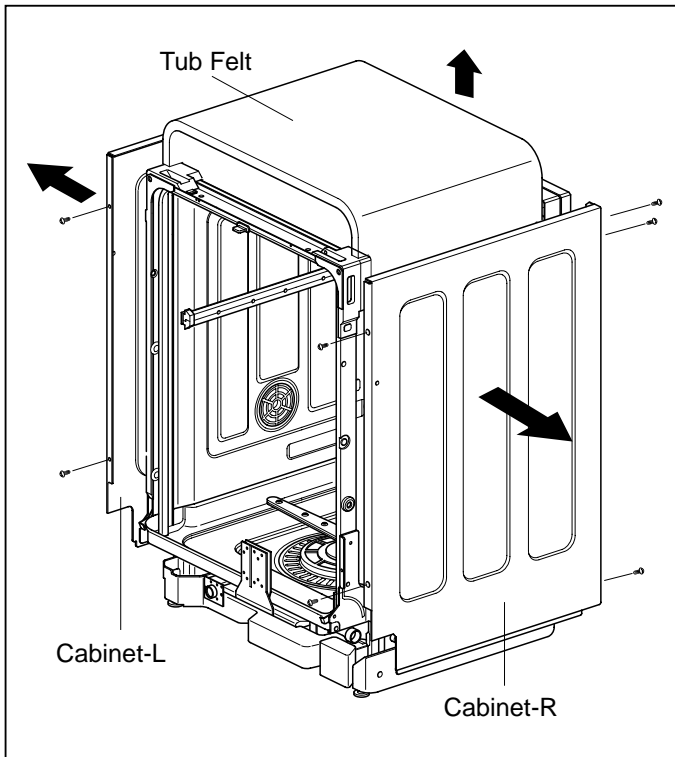

2. Cabinet and Tub Felt

- 1) **Cabinet-R**
 - ① Remove front 2 screws.
 - ② Remove rear 3 screws.
- 2) **Cabinet-L**
 - ① Remove front 2 screws.
 - ② Remove rear 3 screws.
- 3) **Tub Felt**
 - ① Pull the Tub Felt.

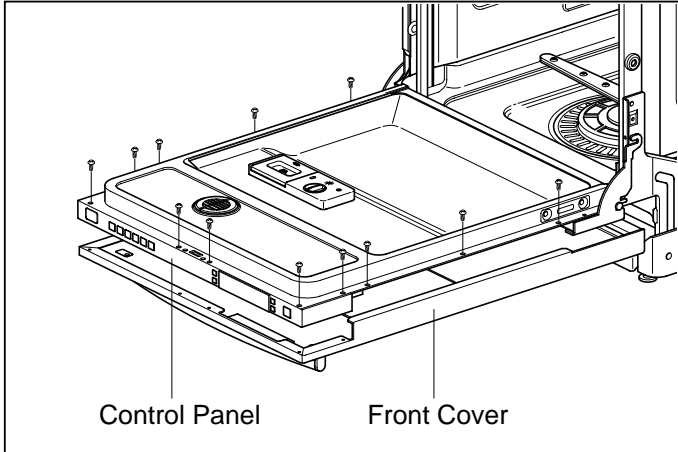

3-1. Door Assembly (LDF 6810/7811/7810 Series)

1) Front Cover

- ① Open the door.
- ② Remove 12 screws(stainless).

2) Control Panel Assembly

- ① Remove 2 screws(Stainless).
 - ② Remove the wire connections.
- Be sure the wiring should not be changed in reassembling
- ③ Remove the Latch assembly.
 - ④ Remove the Front Display.
 - ⑤ Remove 8 screws for Controller.

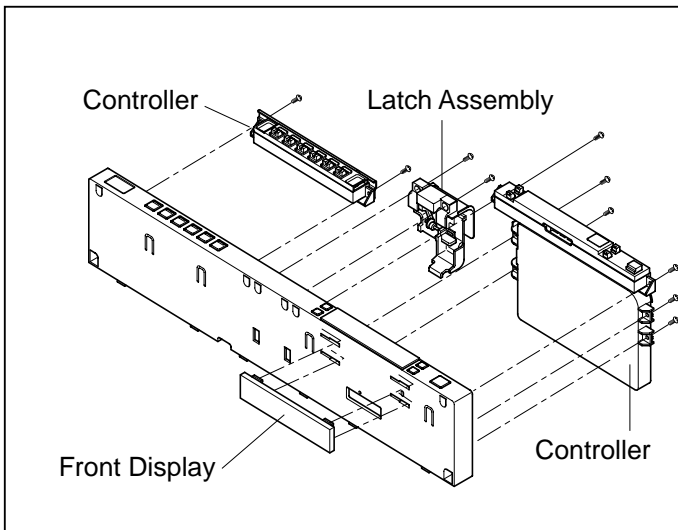
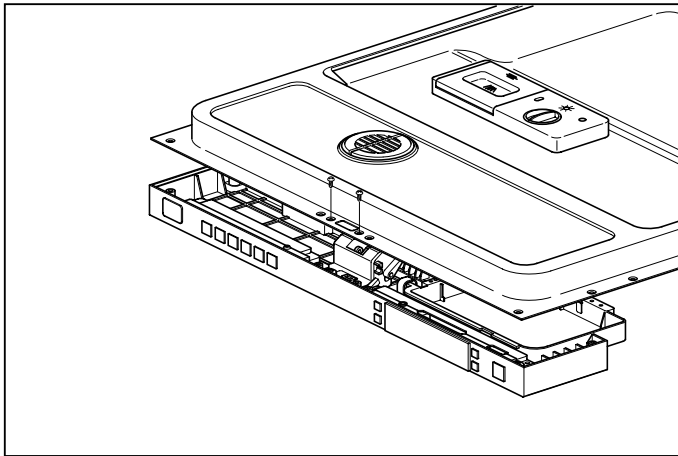

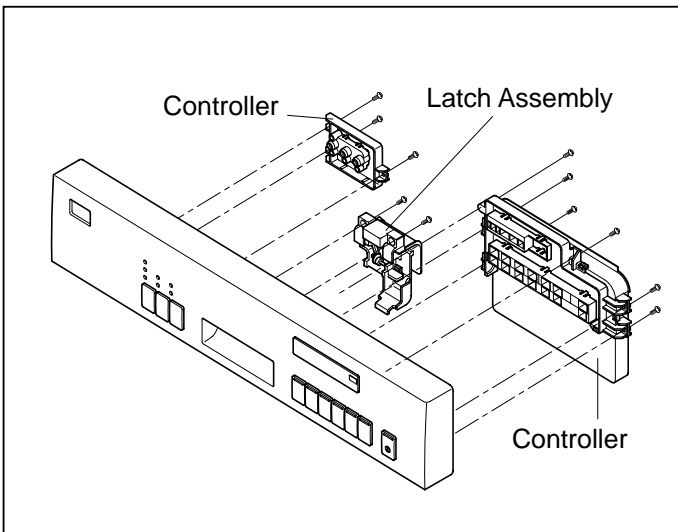
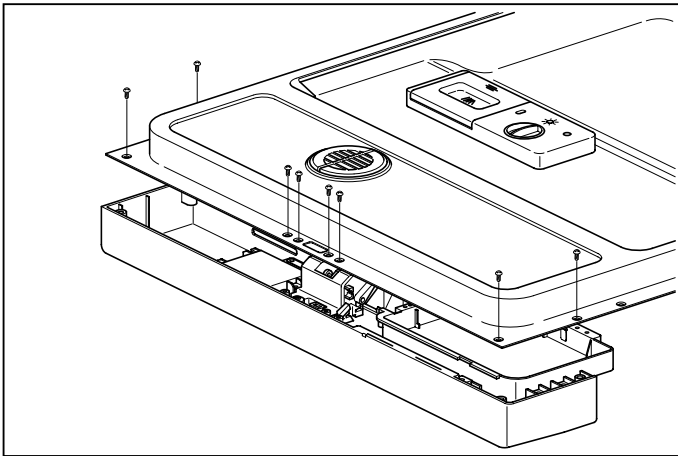
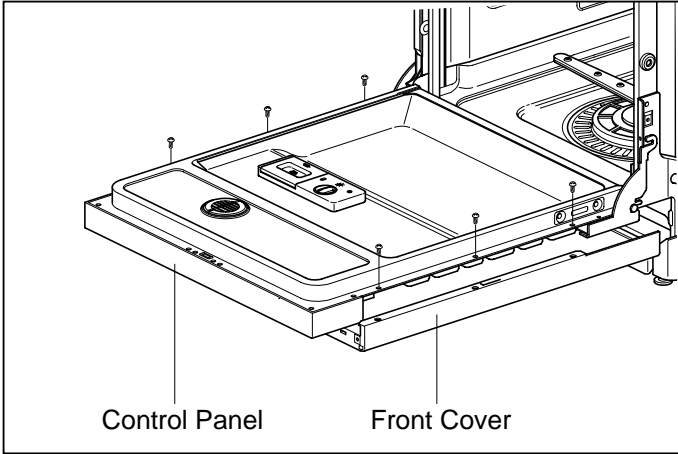

3-2. Door Assembly (LDF 5811 Series)

1) Front Cover

- ① Open the door.
- ② Remove 6 screws(Stainless).

2) Control Panel Assembly

- ① Remove 8 screws(Stainless).
- ② Remove the wire connections.

Be sure the wiring should not be changed in reassembling

- ③ Remove the Latch assembly.
- ④ Remove 8 screws for Controller.

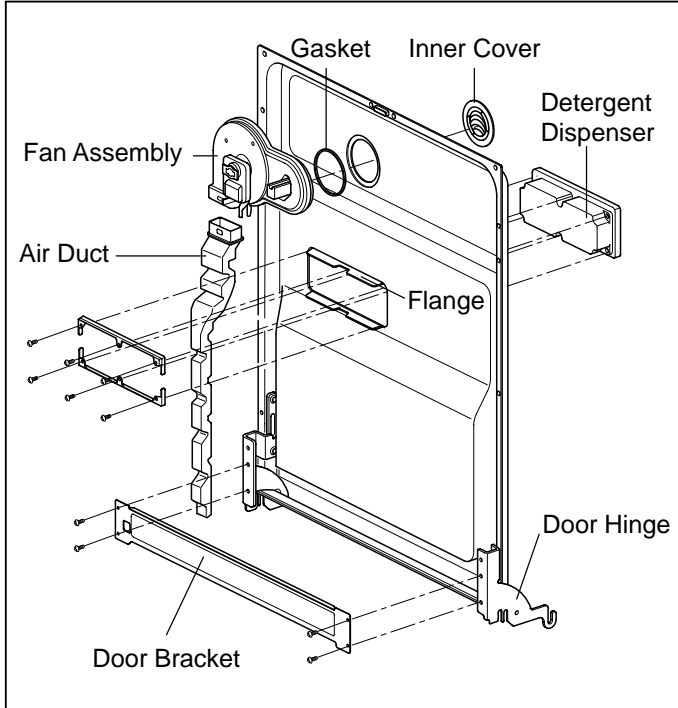

3) Fan Assembly

- ① Open the door.
- ② Remove 4 screws and a earth screw for Door Bracket.
- ③ Remove the wire connetions.
- ④ Remove the Air Duct.
- ⑤ Turn the Inner Cover counterclockwise.

4) Detergent Dispenser

- ① Close the door
- ② Remove the wire connections.
- ③ Remove 6 screws with brackets.
- ④ Push the Detergent slowly pulling up the the Flange by Standard Screwdriver.

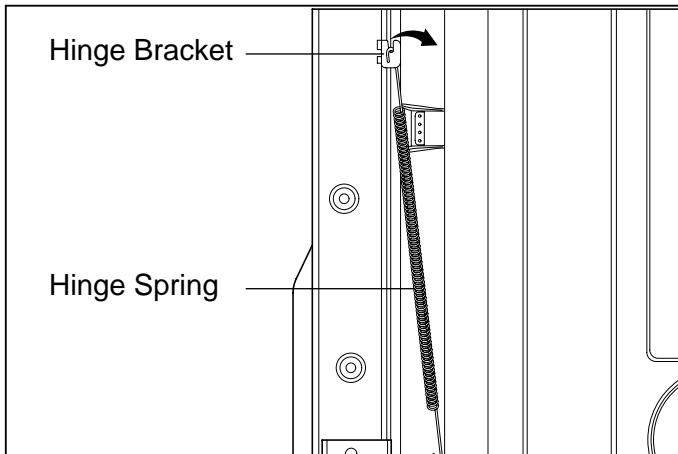

5) Door Spring (Right & Left)

- ① Push the Spring upwards and take it off from the Hinge Bracket.

Be careful not to be injured by the sharpedge of Tub.

- ② Take off the Hinge Link from the Hinge.

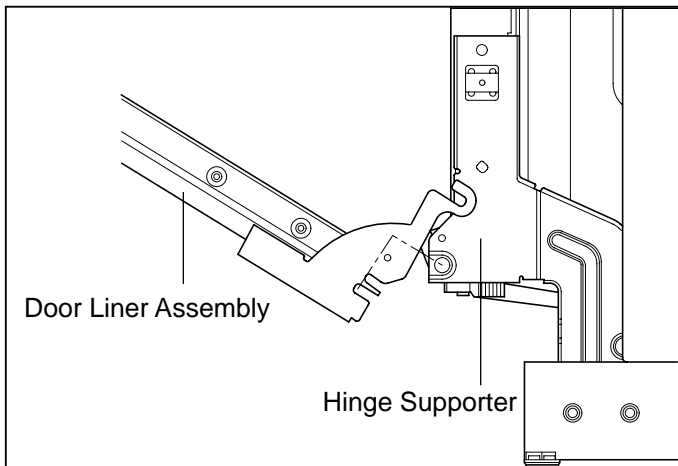

6) Door Liner

- ① Open the door.
- ② Pull the Door Liner and take it off from the Hinge Supporter.

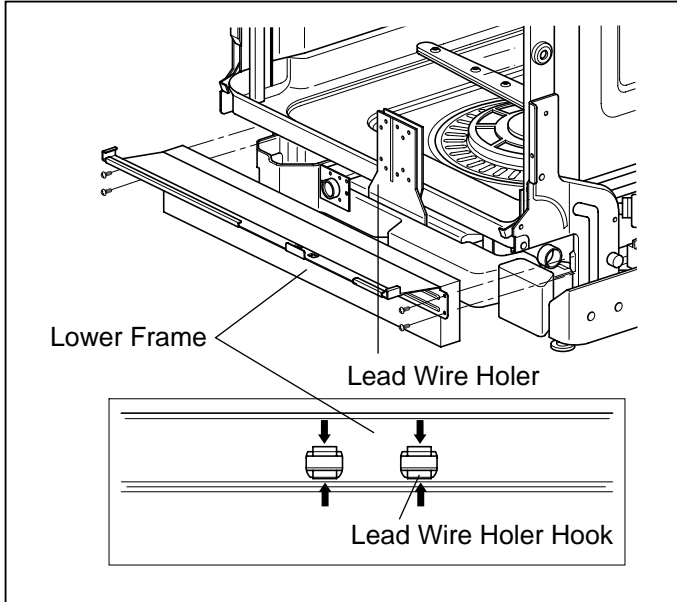

4. Lower Frame

- 1) Press the holder hook as shown in figure.
- 2) Remove 4 screws.

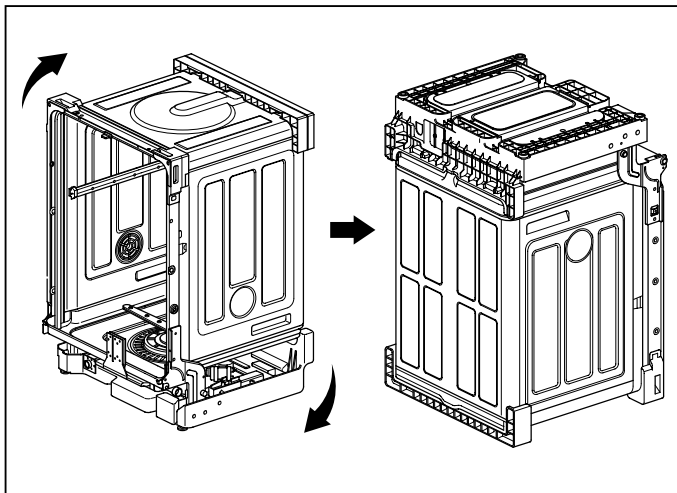

5. Put the Dishwasher upside down.

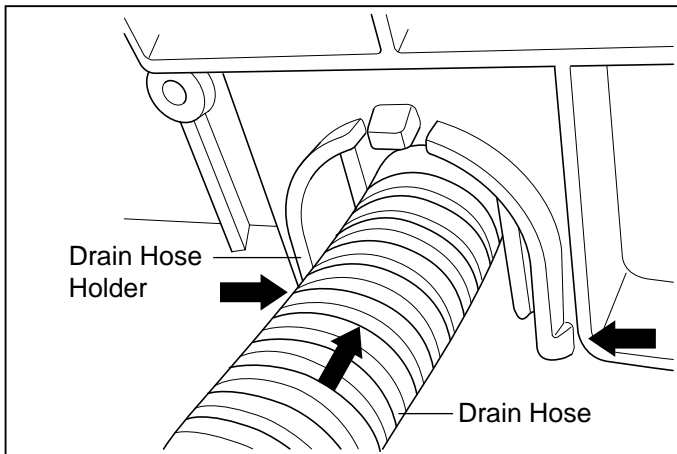

6. Drain Hose Holder

- 1) Press the holder hook as shown in figure.
- 2) Pull the Drain Hose and remove the Drain Hose Holder.

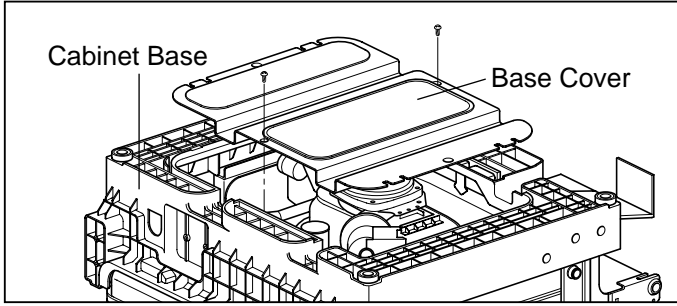

7. Base Cover

- 1) Remove 2 screws.
- 2) Pull the Base Cover out.

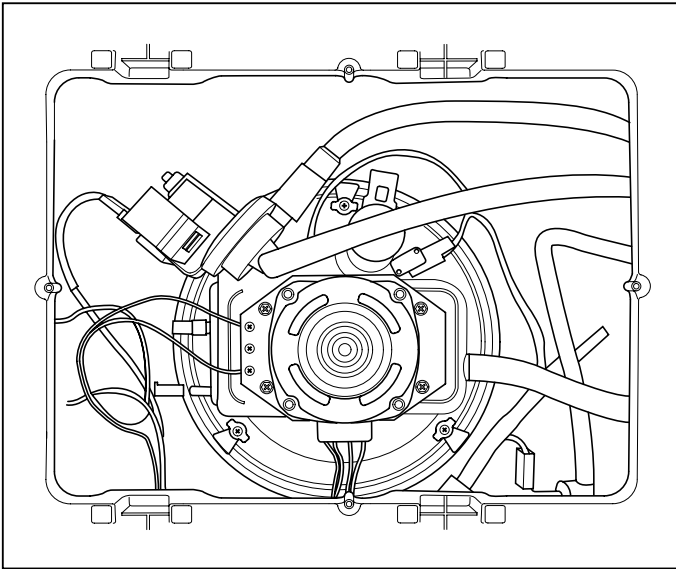

8. Harness & Hose Assembly

- 1) Remove the wiring connections.
- 2) Remove the Hose connections from Sump Assembly.

You can see the information of Wiring Diagram at the back of Lower Cover.

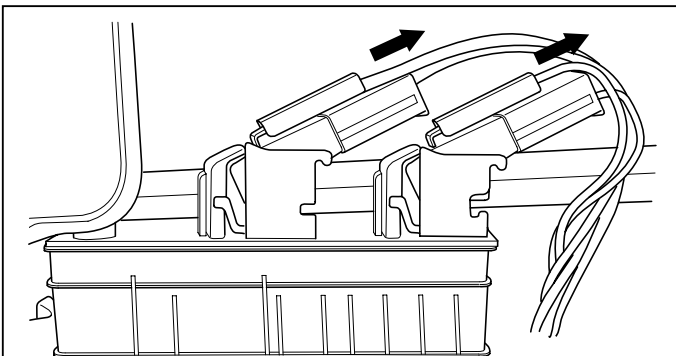
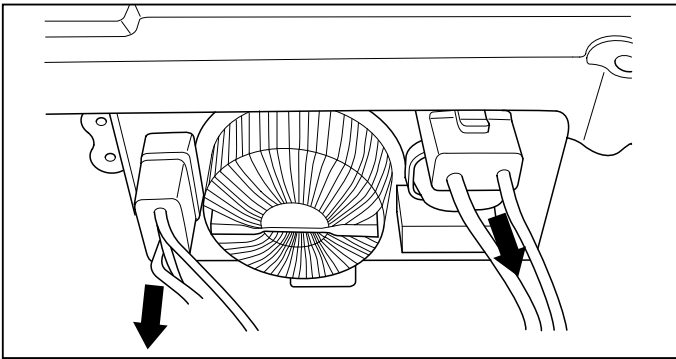

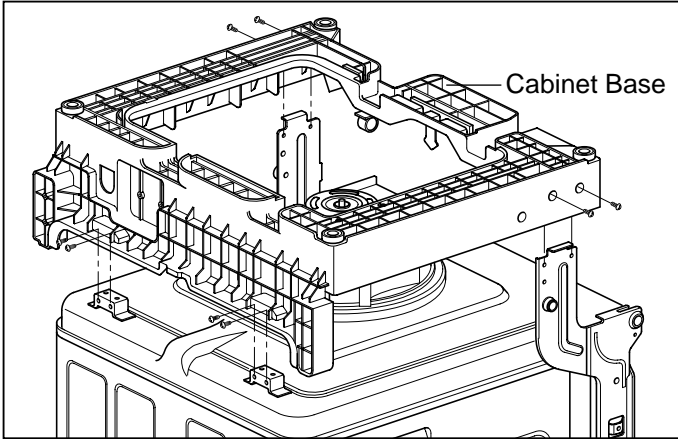

9. Cabinet Base

- 1) Remove 8 screws.
- 2) Lift it upward.

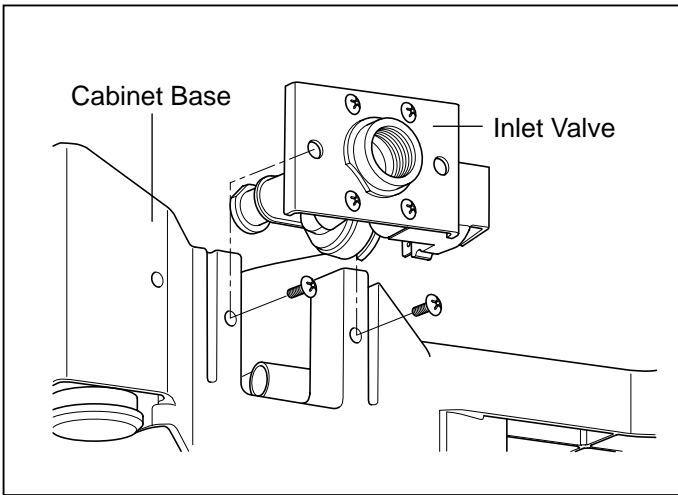

10. Inlet Valve

- 1) You can disassemble the Inlet Valve by removing the 2 screws.

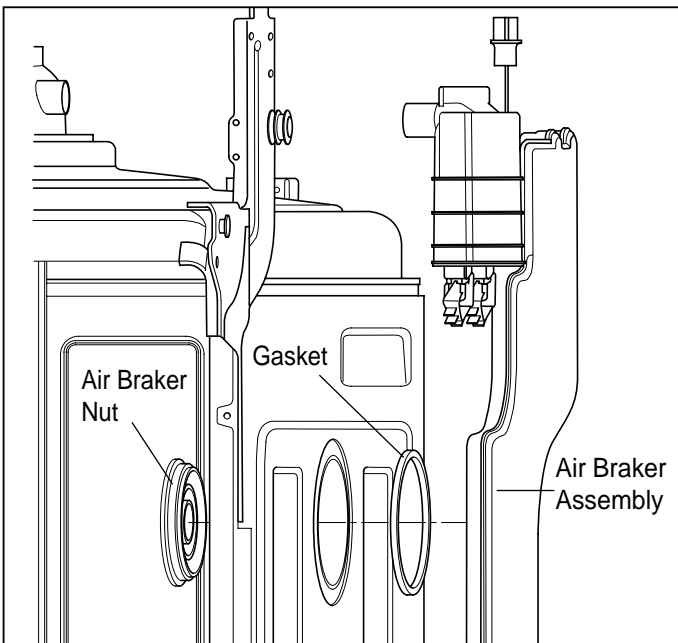

11. Air Braker Assembly

- 1) Disconnect the 3 hoses assembly.
- 2) Turn the Air Braker Nut counterclockwise.

Be careful the o-ring should not be lost.

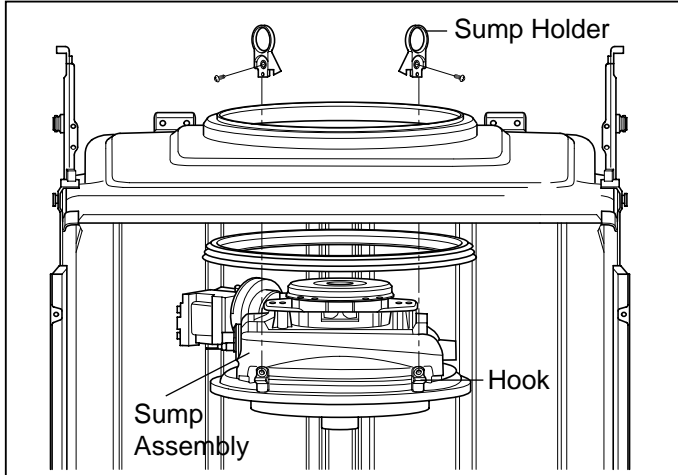

12. Sump Assembly

- ① Remove 2 screws.
- ② Remove the Sump Holder and push the Sump Assembly down with pulling aside Hook.

Be careful not to drop the Sump Assembly to the bottom.

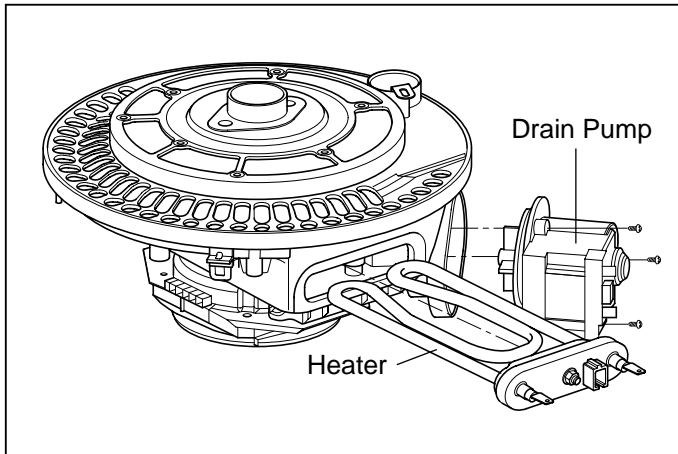

1) Heater & Drain Motor

- ① Pull the Heater out of the Sump after releasing the nut.
- ② Remove 3 screws.

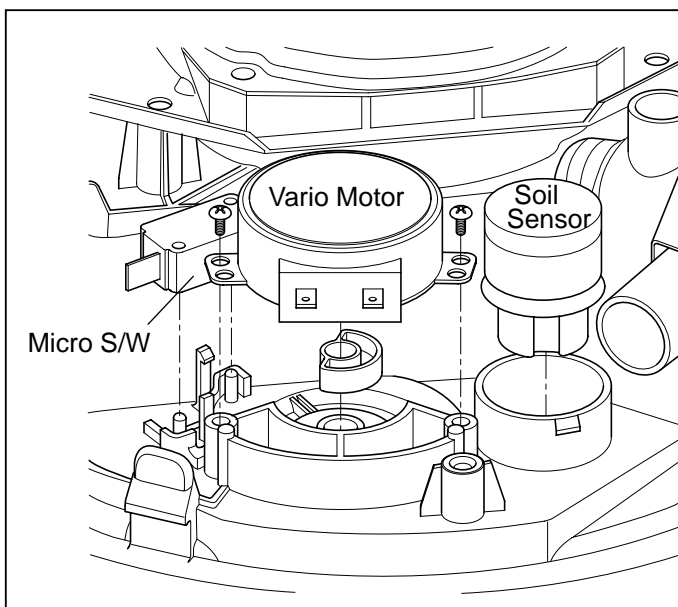

2) Vario Motor & Soil Sensor

- ① Remove 2 screws for Vario Motor.
- ② Pull the Vario Motor, Soil Sensor and Micro S/W.

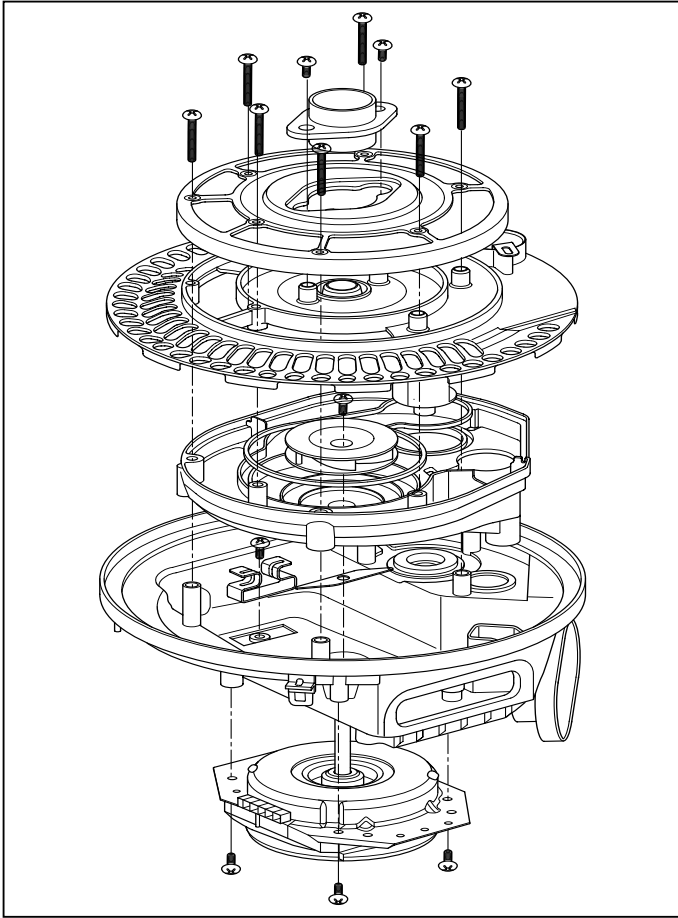

When you reassemble the Sump Assembly, be careful not to kink, tear and take off the seals.

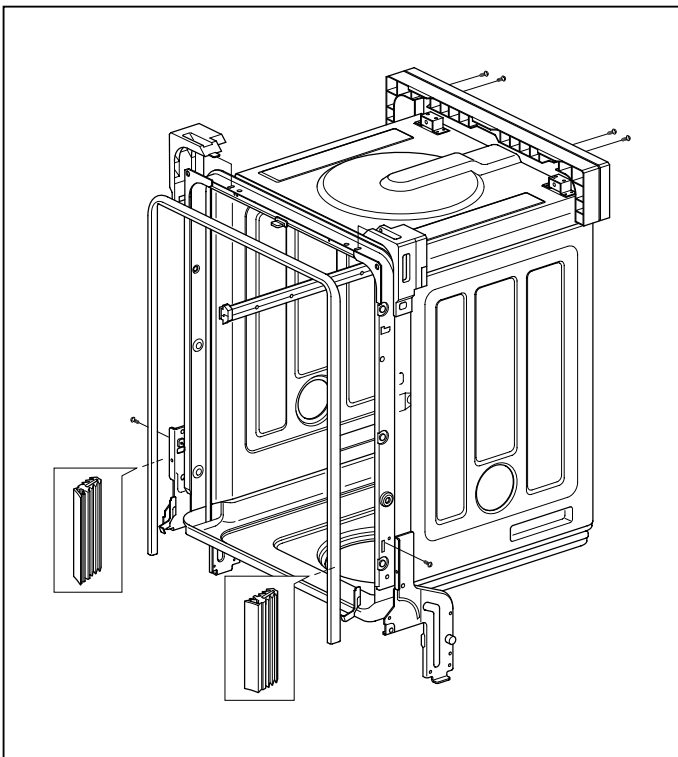

13. Holder Supporter, Tub Packing and Hinge Supporter Assembly.

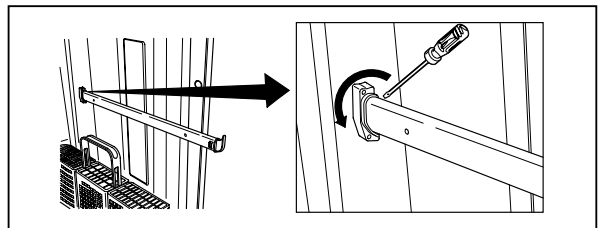







Rotate the screwdriver, after slide it into the gap between Stopper Roller and Rail Roller.

You must take off Stopper Roller(F117) by – screwdriver to change the Rail Assembly. (Stopper Roller could be broken while you are taking off. So you should be careful not to be hurt and have extra stopper rollers ready at servicing at all times)

8.TROUBLE SHOOTING METHODS

A. TROUBLE SHOOTING ACCORDING TO DISPLAYED ERROR MESSAGE

ERROR MESSAGE	POSSIBLE CAUSE FOR ERROR OCCURRENCE	REMEDY
<p>INLET ERROR</p>  <p>displayed</p> <p>Condition Not reached to the normal water level in spite of 10 min. water supply</p>	<ul style="list-style-type: none"> • The Water Supply Tap is closed. • The Water Supply is shut off. • The Inlet Hose is kinked. • The Water Pressure is very low. (below 10 psi) • Inlet Valve is OK? • The filter of Inlet Valve is clogged by impure water. • The Hall sensor is OK? • The Impeller of Air Guide is bound. 	<ul style="list-style-type: none"> • Take action on Water Supply device. • Measure the electric resistance of Inlet Valve. (950-1300 Ω) • Clean the filter of Inlet Valve. • Check the frequency of Inlet Water by the Test Mode. • Replace the Air Braker.
<p>DRAIN ERROR</p>  <p>displayed</p> <p>Condition Not fully drained out in spite of 5 min. drain operation</p>	<ul style="list-style-type: none"> • The Drain Hose kinked or blocked. • Wiring connection is OK? • The drain outlet of sump is blocked. • The Drain Pump/Motor or circuit is troubled. 	<ul style="list-style-type: none"> • Remove the cause of kink or block. • Check the wiring connection. • Measure the electric resistance of Drain Motor. (20-40 Ω) • Replace the Drain Motor or repair the Circuit.
<p>LEAKAGE ERROR</p>  <p>displayed</p> <p>Condition The excessive RPM of Washing Motor happened during Wash cycle due to water leakage.</p>	<ul style="list-style-type: none"> • Water leakage in Hose connections. • Water is leaked by damages. • The Motor Water Seal leakage of Sump assembly. • The height of Drain Hose connection (sink-Drain Hose) is not over 20". • Impeller of the Washing Pump is worn away. 	<ul style="list-style-type: none"> • Replace the connections of Hose. • Check the point of damages and repair or replace the related parts. • Read the Installation Instructions (page 9) and fix it to the recommended Height. • Replace the Impeller of the Washing Pump.

ERROR MESSAGE	POSSIBLE CAUSE FOR ERROR OCCURRENCE	REMEDY
<p>EXCESS ERROR</p>  <p>displayed</p> <p>Condition</p> <p>Excessive water is supplied than normal water level.(Automatically drain Pump operated.)</p>	<ul style="list-style-type: none"> • The Inlet Valve is troubled. • The Controller is troubled. 	<ul style="list-style-type: none"> • Replace the Inlet Valve. • Repair or replace the Controller.
<p>THERMAL ERROR</p>  <p>displayed</p> <p>Condition</p> <p>The resistance of thermistor not normally out put.</p>	<ul style="list-style-type: none"> • The Inlet Water Temperature is very high. (over 194°F) • Wiring connection is OK? • The Thermistor is OK? 	<p>Check the temperature. (Test Mode)</p> <ol style="list-style-type: none"> 1) If the temperature is displayed, <ul style="list-style-type: none"> ① adjust the Inlet Water Temperature to 120°F. 2) If the temperature is not displayed, <ul style="list-style-type: none"> ① check the wiring connection. ② check the electric resistance of Thermistor. (11~14k Ω at 77°F) ③ Replace the PCB.
<p>MOTOR ERROR</p>  <p>displayed</p> <p>Condition</p> <p>The Motor is working abnormally.</p>	<ul style="list-style-type: none"> • Wiring connection is OK? • The Impeller of Washing Pump is locked. • The rotor of Washing Motor is locked. • The Blade is locked. 	<ul style="list-style-type: none"> • Check the wiring connection. • Replace the cause of restriction. • Replace the Washing Motor. • Replace the PCB.

B. TROUBLE DIAGNOSES AND REPAIR BY SYMPTOM

No Power on when the power button pressed.

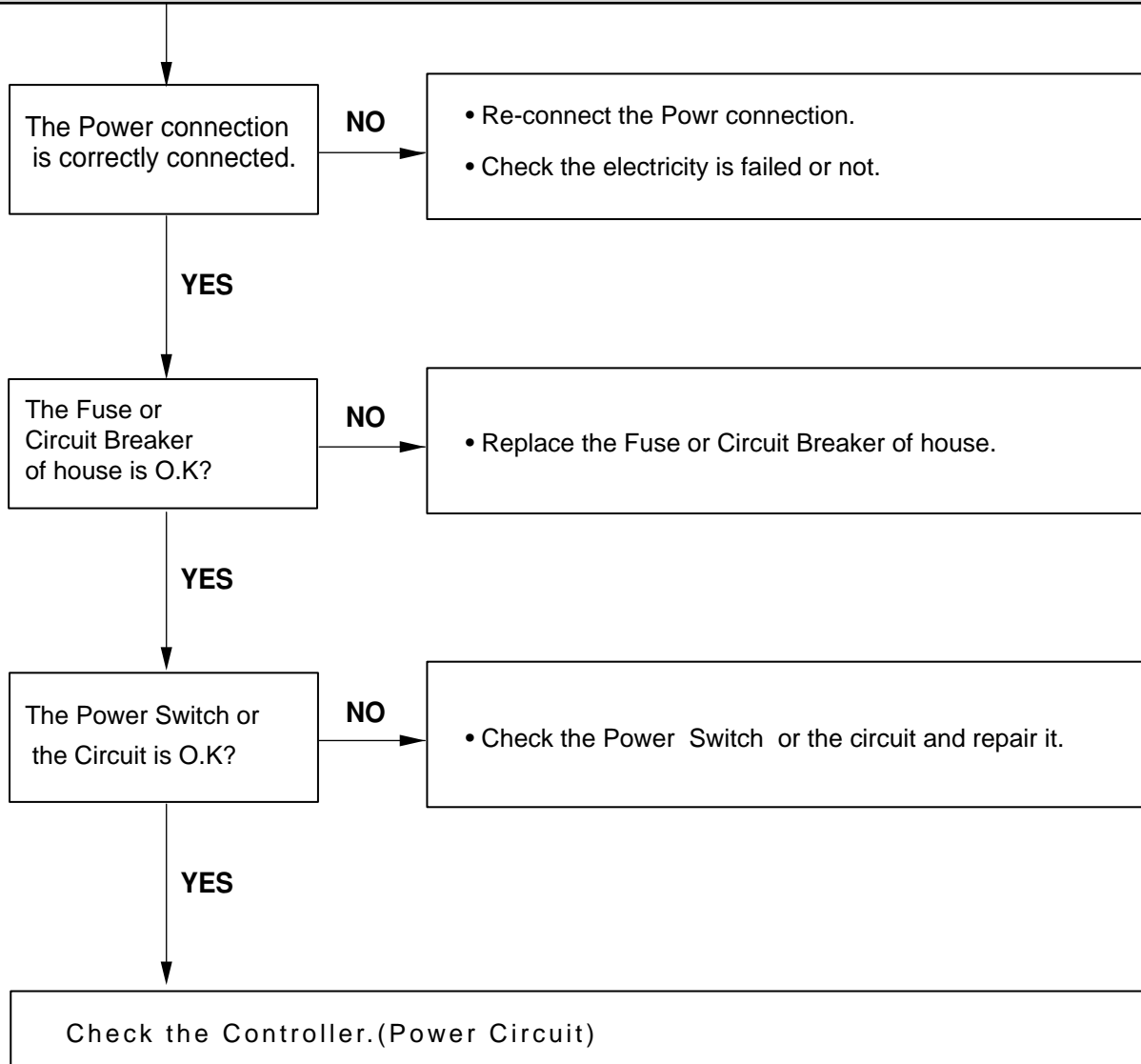

The Wash Pump/Motor does not run.

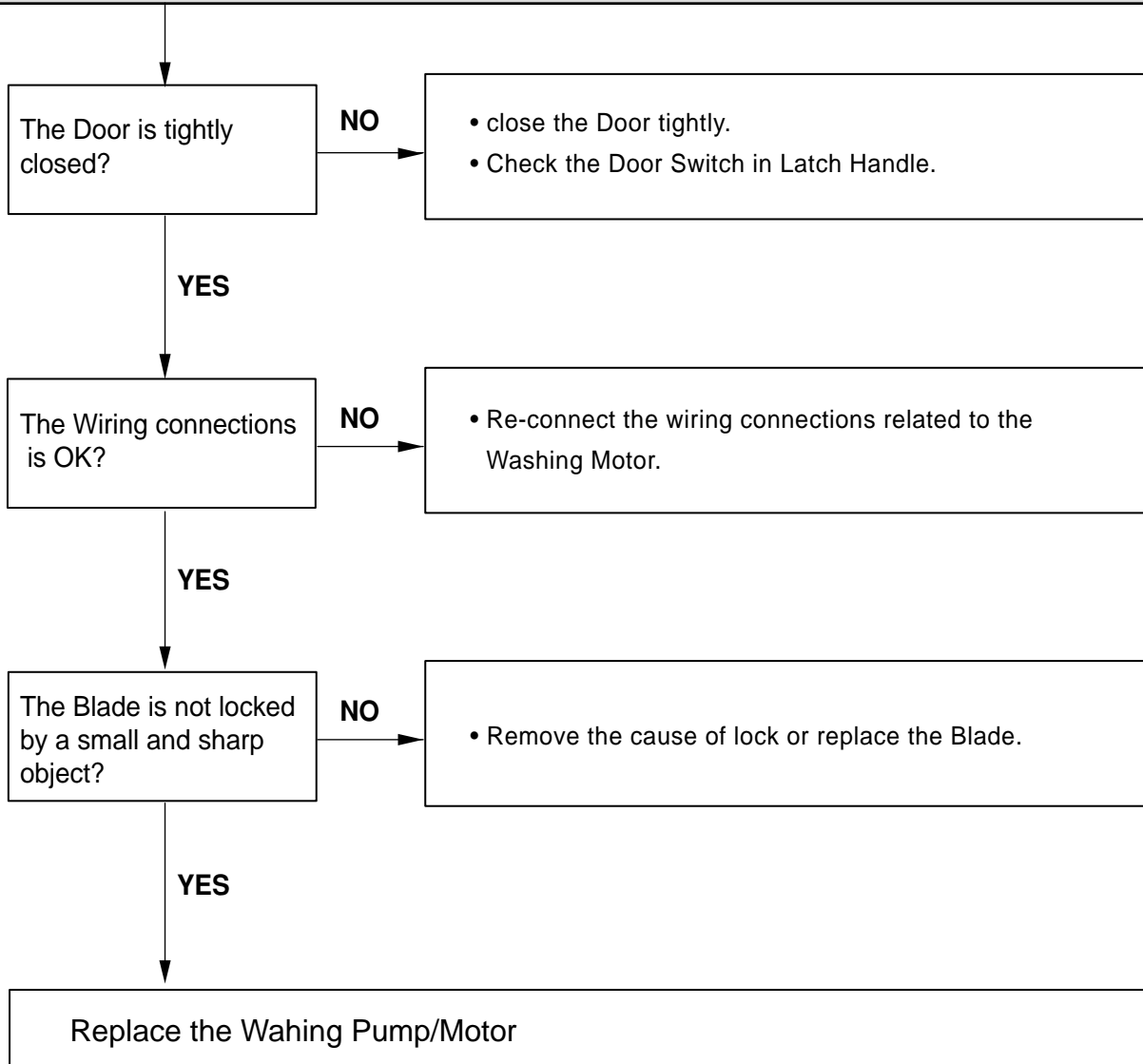

Washing Results are not Satisfactory

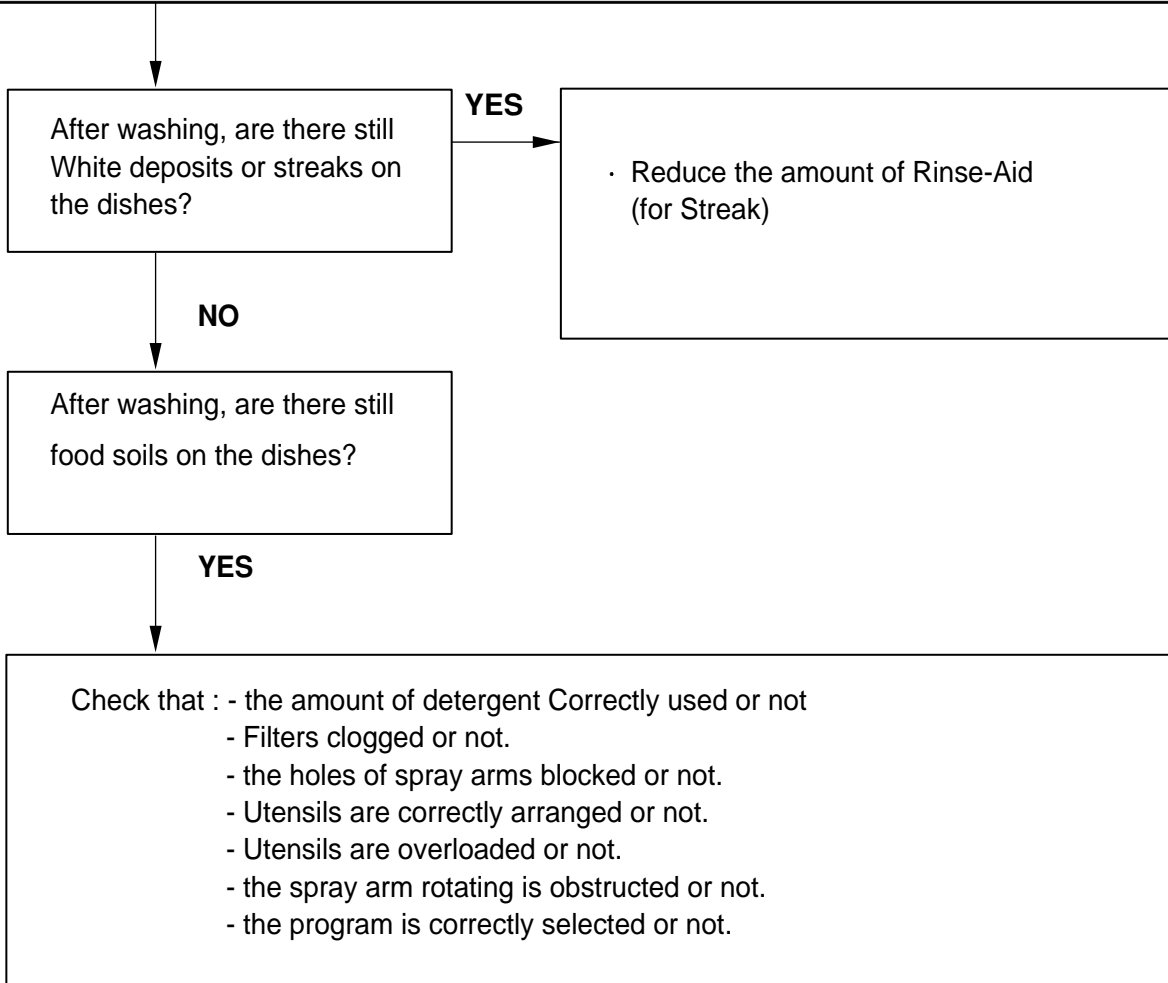

Dry Results are not satisfactory

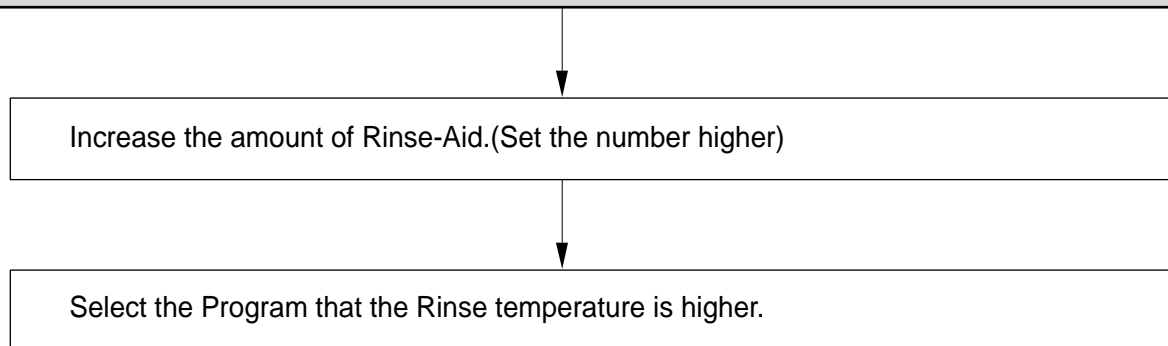

Power Button not automatically off after operation.

Check the button is blocked by foreign materials.

Check the Power Switch.(Replace it, if necessary.)

Check the Controller.(Replace it, if necessary.)

9. INSTALLATION INSTRUCTION

Step 1: PREPARE CUPBOARD OPENING

1. This dishwasher is designed to fit a standard dishwasher opening as shown below.
2. Select a location as close to sink as possible for easy connections to water and drain lines.
3. The dishwasher should not be installed more than 10 ft. (3m) from the sink for proper drainage.
4. If dishwasher is to be installed in a corner, a minimum of 2 in. (50mm) is required between the dishwasher and an adjacent a wall.

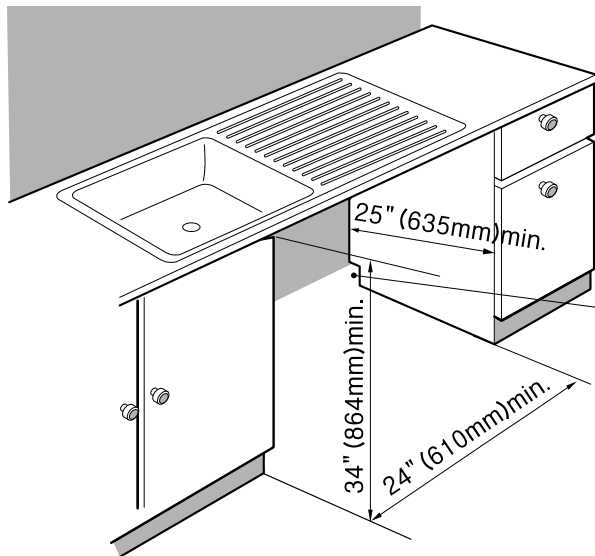

If dishwasher will sit directly on subflooring, subfloor should be sealed with a waterproof paint or sealer to prevent damage from steam.

Drill a 1-1/2" (38mm) dia hole or cut out for drain hose, inlet hose and electrical cables on either side.

approx. 4" (100mm, W) X 4" (100mm, H)
These openings must be within 4" (100mm) from the floor and 1-5/8" (40mm) from the back wall. If there is a floor in the cabinet under the sink, it will also be necessary to drill or cut through the floor to connect the water and drain under the sink.

- Ensure the floor under the dishwasher is at the same level as the rest of the room to allow for any service requirements.

Step 2: PREPARE THE ELECTRICAL WIRING



WARNING!

For personal safety, remove house fuse or open circuit breaker before installation. Do not use an extension cord or adapter plug with this dishwasher. Electrical and grounding connections must comply with the national electrical code/provincial and municipal code and/or other local codes.

1. This appliance must be operated with correct voltage as shown in this manual and on the rating plate, and connected to an individual, properly grounded branch circuit, protected by time delay fuse. Wiring must be 3 wires including ground.
2. The wiring or cord should be in an accessible location adjacent to, and not behind the dishwasher and within 4 ft. (1.2m) of the dishwasher side.
3. The wiring or cord must be grounded properly, if in doubt, have it checked by a qualified electrician. No other appliance shall be connected to the same outlet by a double adapter or similar plug.
4. The wiring or cord must be oriented as shown in Figure A below.
5. Check the dishwasher for any damage before trying to install it.
6. Make sure water line and Electrical line are oriented in the bottom channels as shown in the figure below.
If you find any damage to the dishwasher, Please contact your dealer or builder immediately.

Figure A

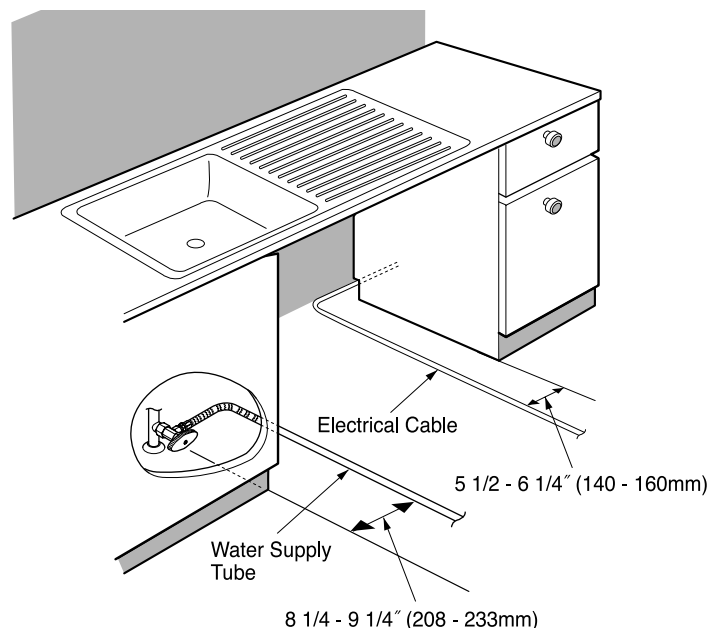

Step 3: PREPARE THE WATER SUPPLY CONNECTION

1. This dishwasher may be connected to either hot or cold water. If the water can not be maintained below 149°F (65 °C), the dishwasher must be connected to cold water.
2. When connecting the dishwasher water line, sealing tape or compound should be used to avoid leaks.
3. When connecting the dishwasher water line, the house supply should be shut off.
4. The Water Supply Tube must be oriented as shown in Figure A on page 6.

Step 4: PREPARE DISHWASHER FOR INSTALLATION

1. Adjust the legs to the required height to fit properly under the countertop as shown below.
2. Check the level of dishwasher by using level.

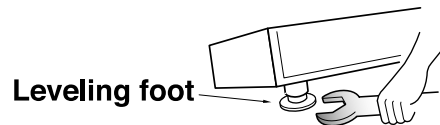

Step 5: INSTALL THE DISHWASHER IN CUPBOARD

1. Remove the Lower Cover and orient dishwasher as shown below.
2. Before sliding the dishwasher into the cupboard opening, make all necessary height adjustments using the legs.
3. Slide the dishwasher into the cabinet opening carefully. Make sure that the drain hose inside the cabinet is not kinked.
4. Follow the instruction as in Figure B.

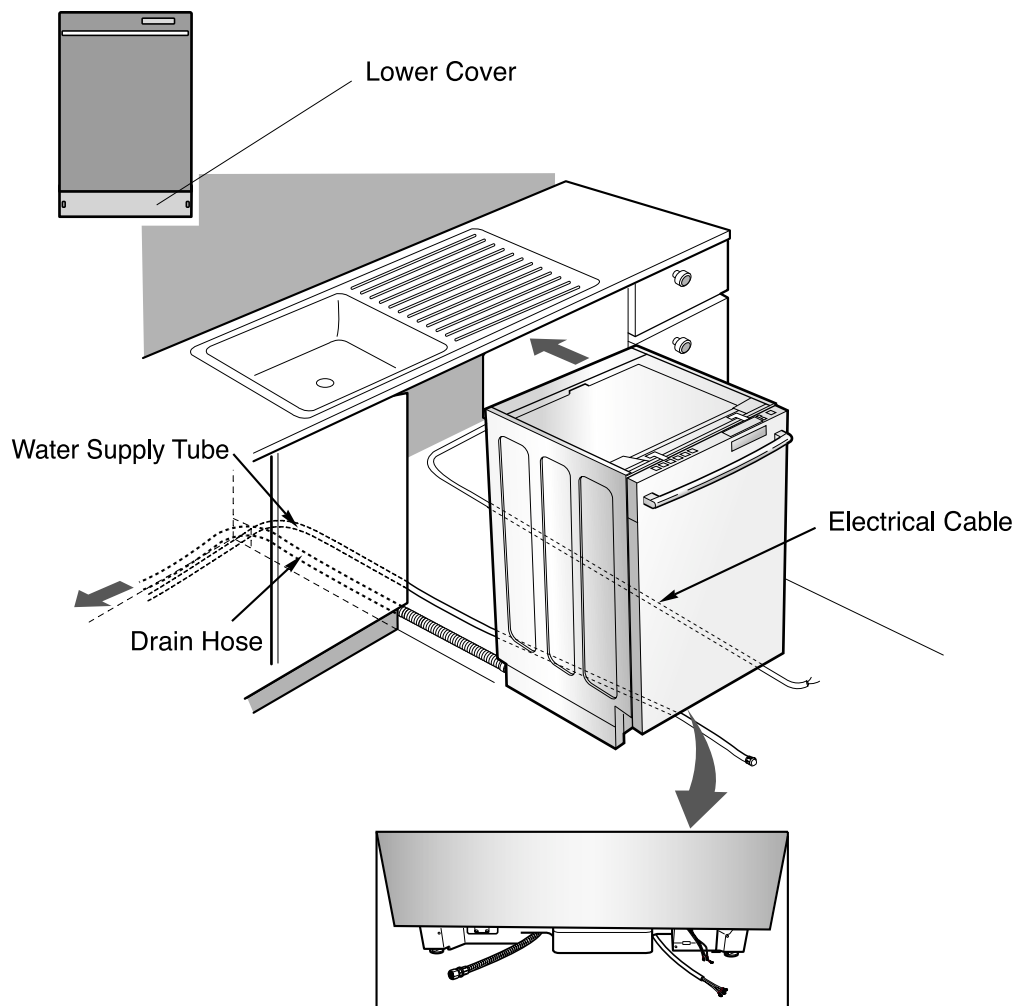

Step 6: DRAIN LINE CONNECTION

1. If the end of the drain hose does not fit to the drain line, use an adapter (not supplied) that must be resistant to heat and detergent and may be obtained from a plumbing shop.
2. There are 2 typical connections as shown in Figures C & D.
 - ① There may be other options than shown here for connection the drain hose. The drain connection must meet local plumbing regulations.
 - ② The S trap spigot must be drilled out cleanly and free of obstruction to its maximum internal diameter, if used for drainage.
 - ③ To prevent syphoning, one of the following instruction methods must be followed:

Figure C: Connection to Disposer or waste Tee.

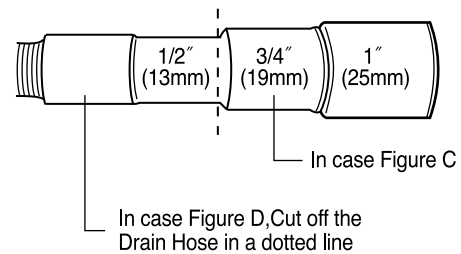
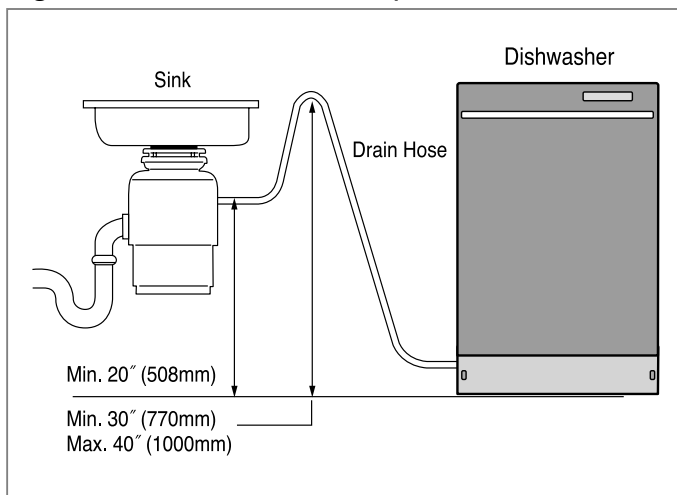
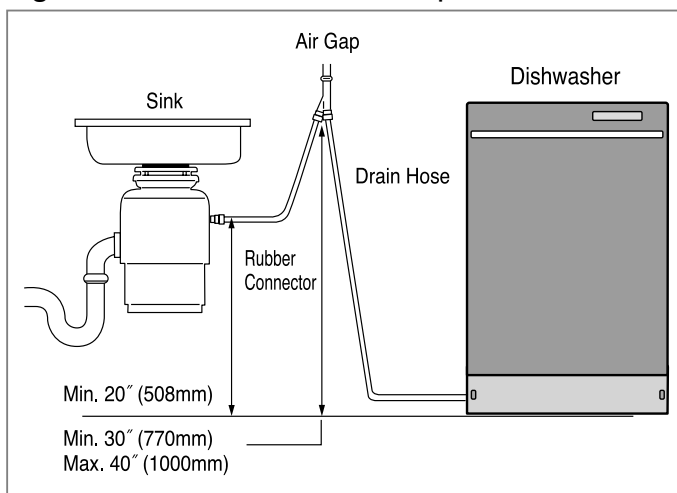

Figure D: Connection to Air Gap.



Drain Requirements

- Follow local codes and ordinances.
- Do not exceed 10 ft. (3m) distance to drain.
- Do not connect drain lines from other devices to the dishwasher drain hose.

Step 7: WATER SUPPLY CONNECTION

1. When connecting, sealing tape or sealing compound should be used to avoid water leaks.
2. Before connecting, turn off the water supply.
3. After fitting the Elbow into the Inlet Valve, slide the Flexible Stainless Tube or Copper Tube into the Elbow.
4. Tighten the nut and make sure that the line is not kinked or sharply bent.

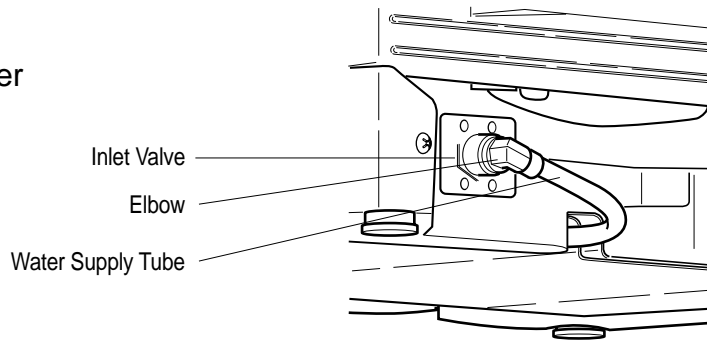

Step 8: ELECTRICAL POWER CONNECTION

1. Before beginning, turn off electrical power to the unit at the circuit breaker.
2. Remove the Junction Cover and then Install the Strain Relief.
3. Twist Wire Connectors tightly on the wires. Wrap each connection with Electrical tape.
4. Check again and make sure that all wires are connected correctly, black to black, white to white, green to green (ground to ground).
5. Replace the Junction Cover.

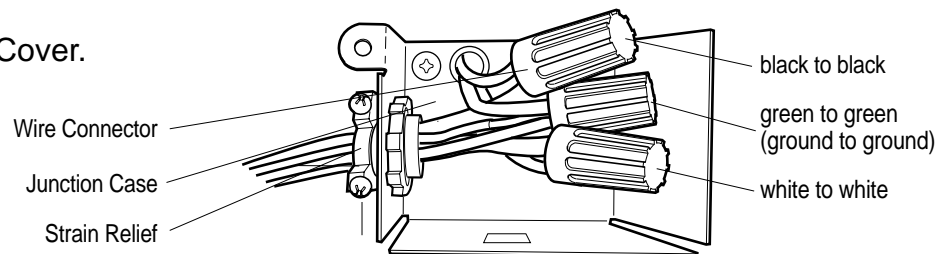
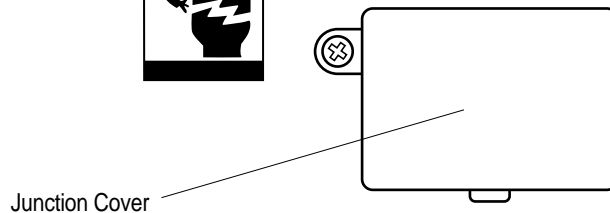

Step 9: FINAL CHECKS

1. Turn electrical power back on at the circuit breaker.
2. Turn house water supply back on.
3. Operate the dishwasher through one cycle (Quick cycle is recommended) to check for water leaks and operating conditions.
4. Replace the Lower Cover.

10. EXPLODED VIEW

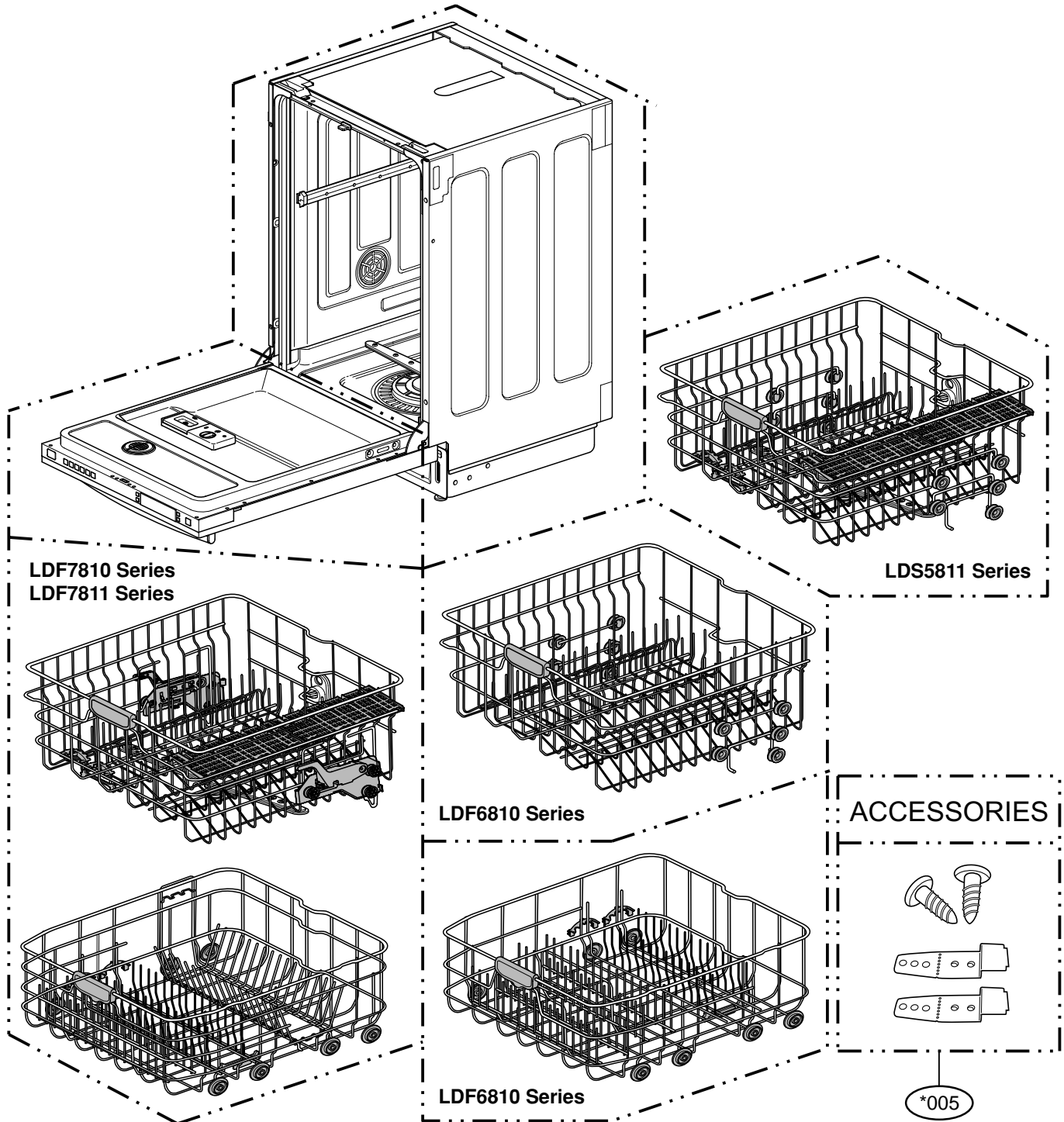

EXPLODED VIEW

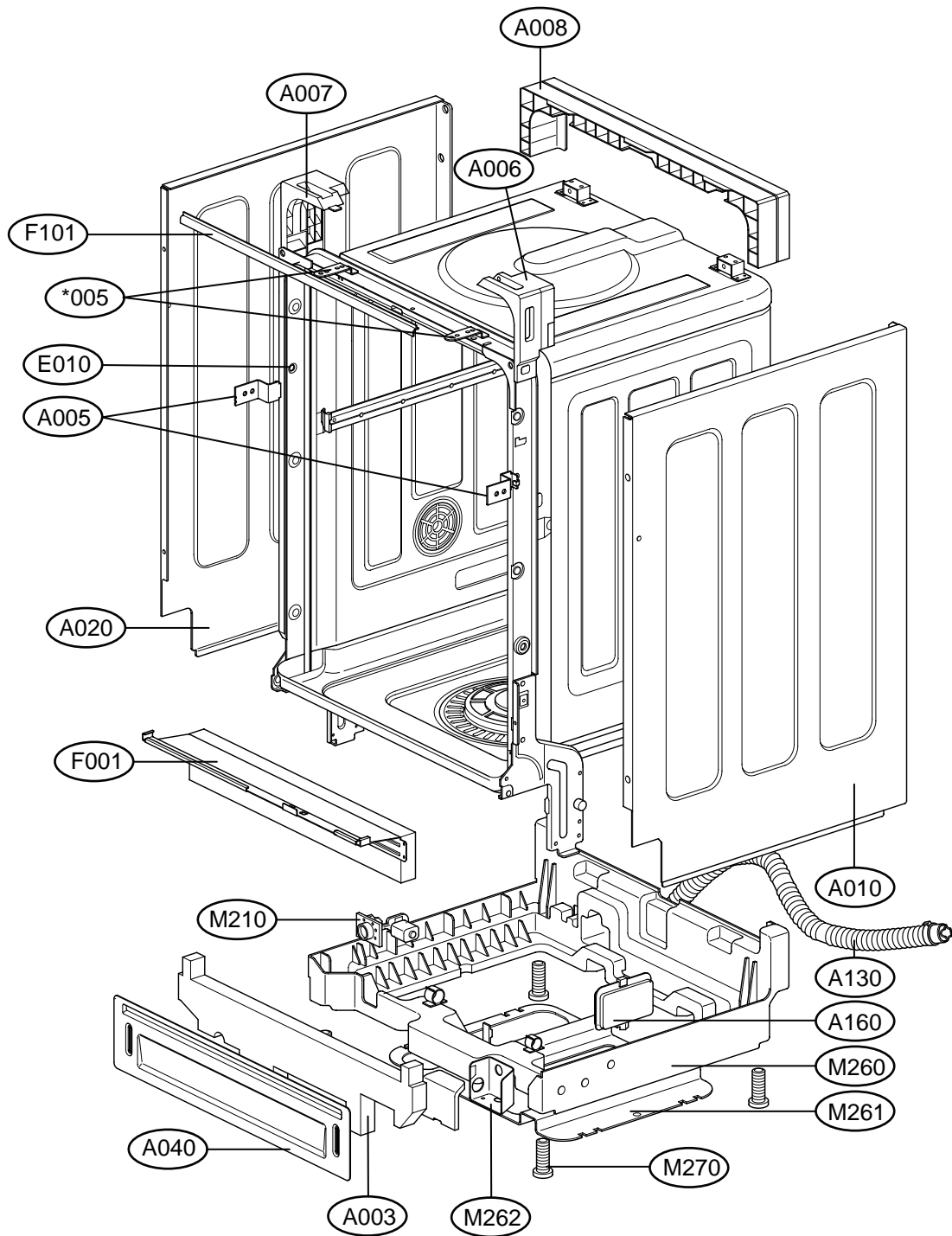

EXPLODED VIEW - TUB ASSEMBLY

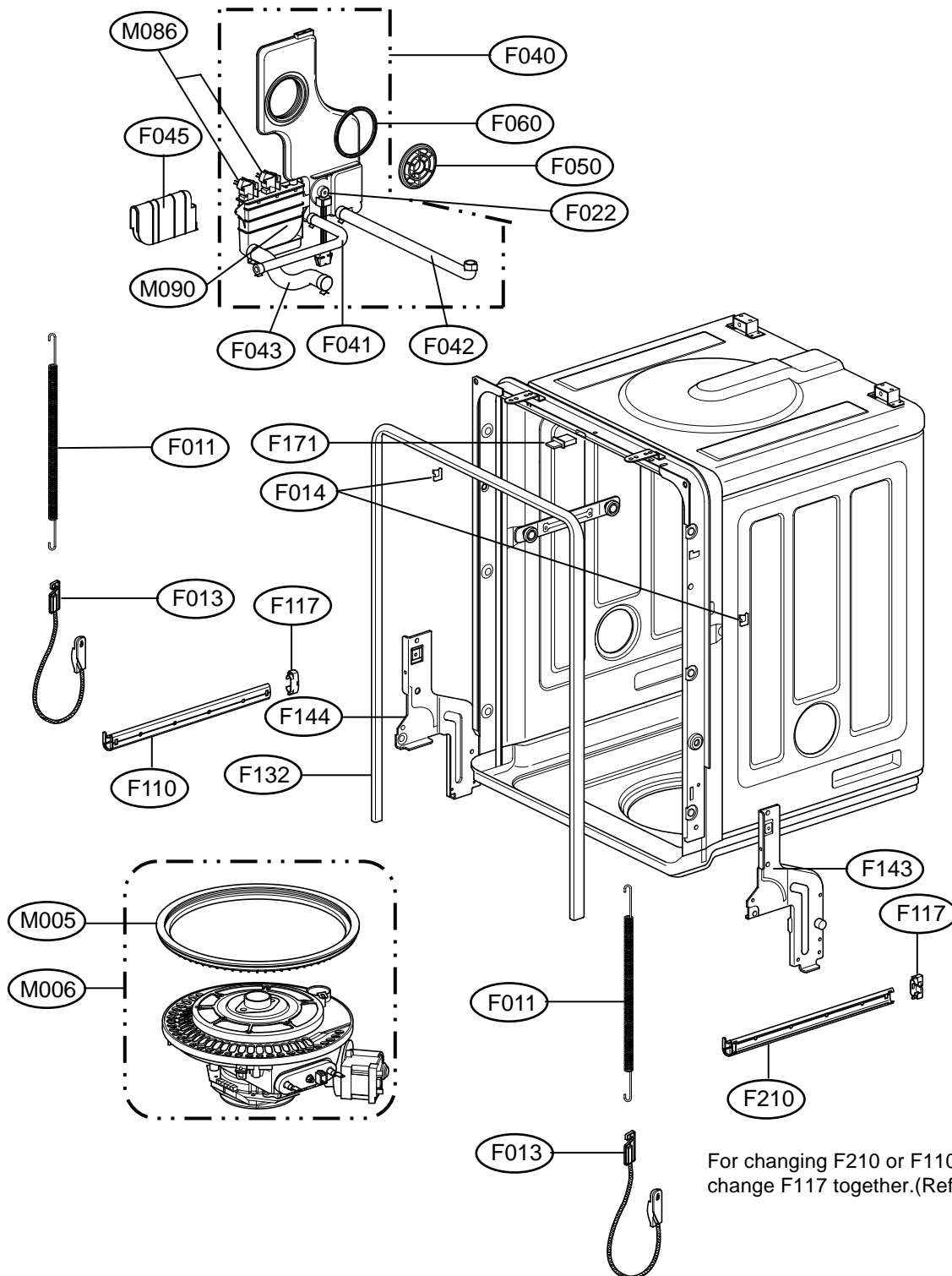

For changing F210 or F110, you must change F117 together.(Ref 24page)

EXPLODED VIEW - RACK ASSEMBLY (LDF7811/7810 LDS5811 Series)

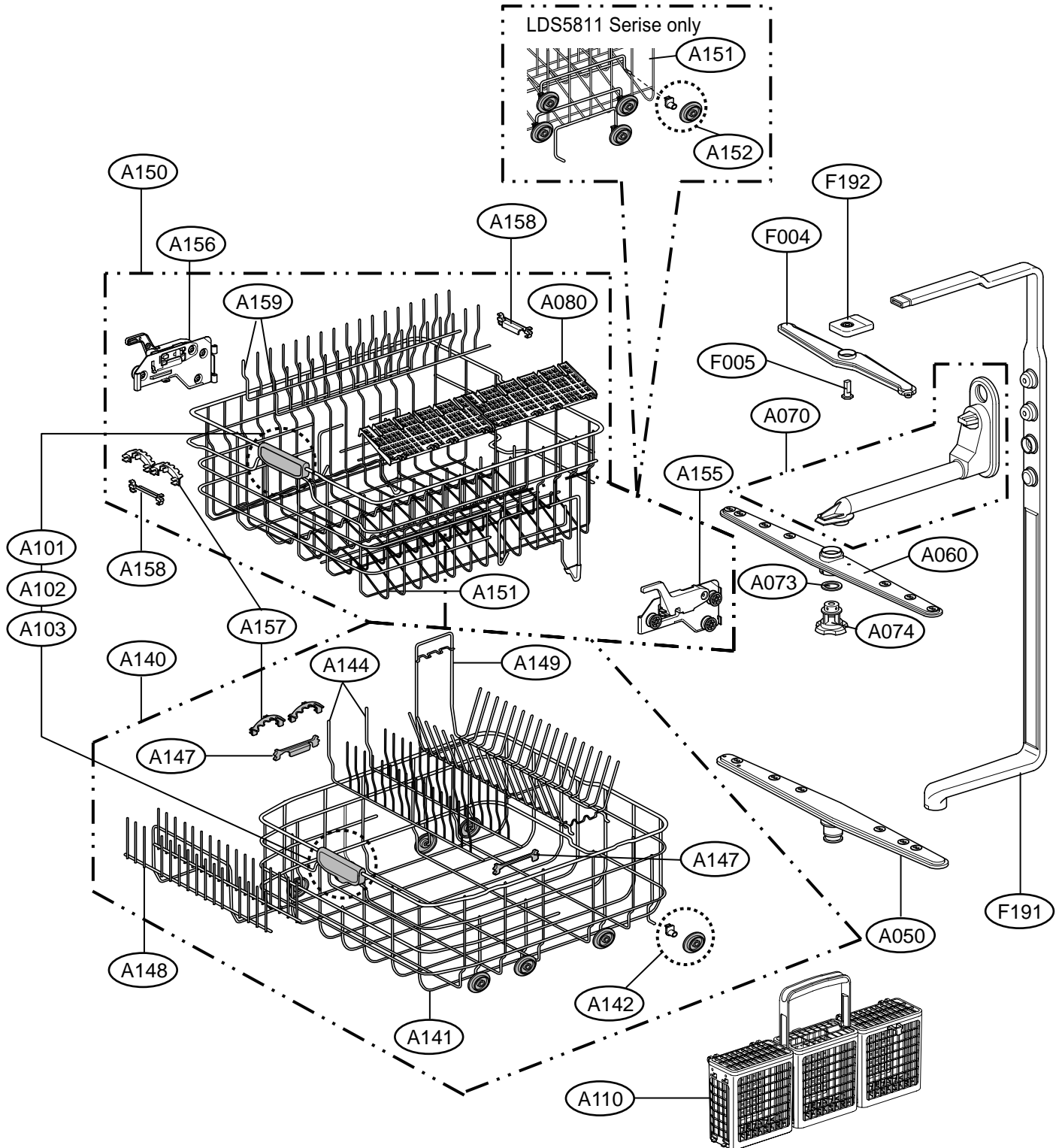

EXPLODED VIEW - RACK ASSEMBLY (LDF6810 Series)

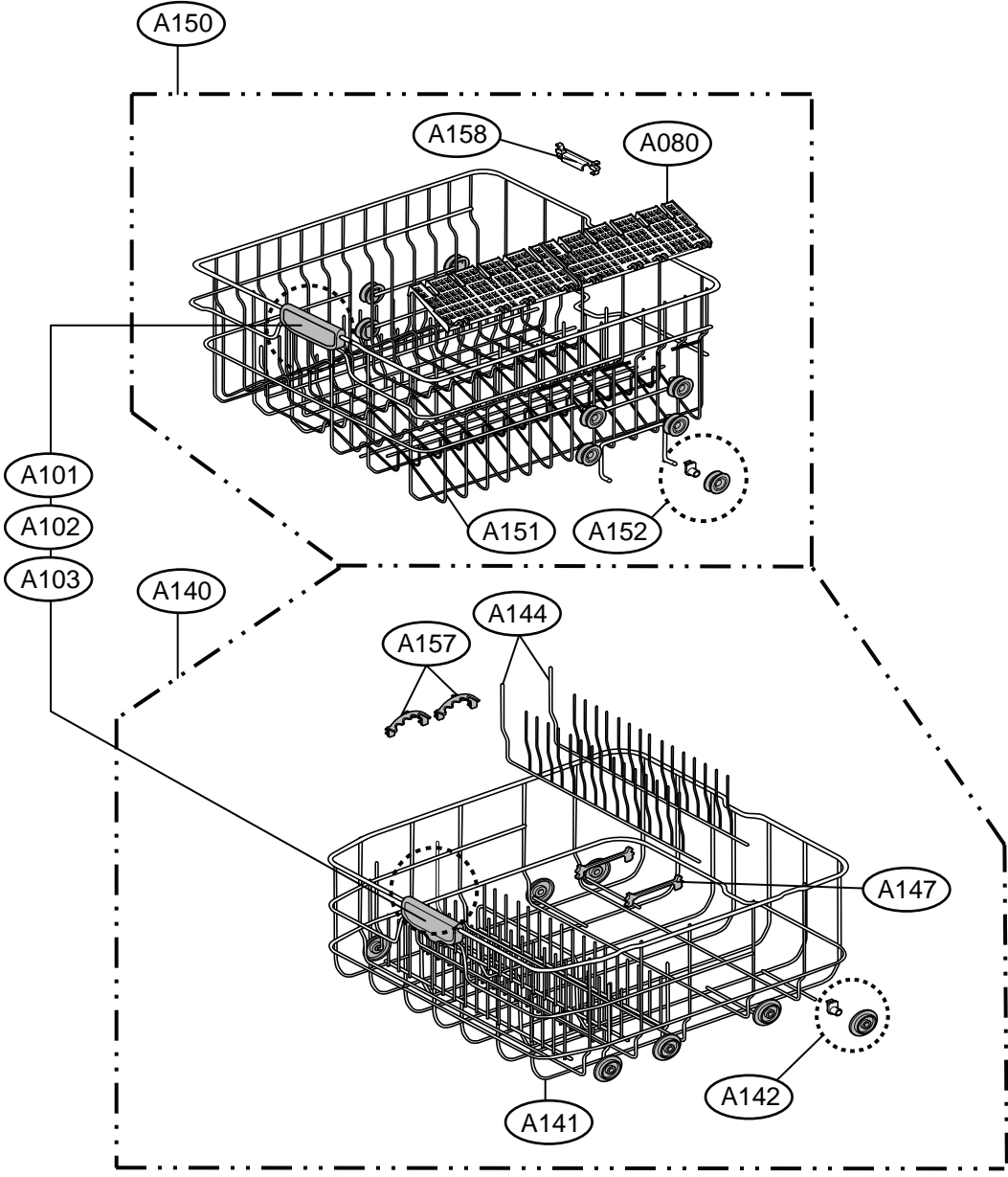

EXPLODED VIEW - PANEL ASSEMBLY (LDF7811/7810 LDS5811 Series)

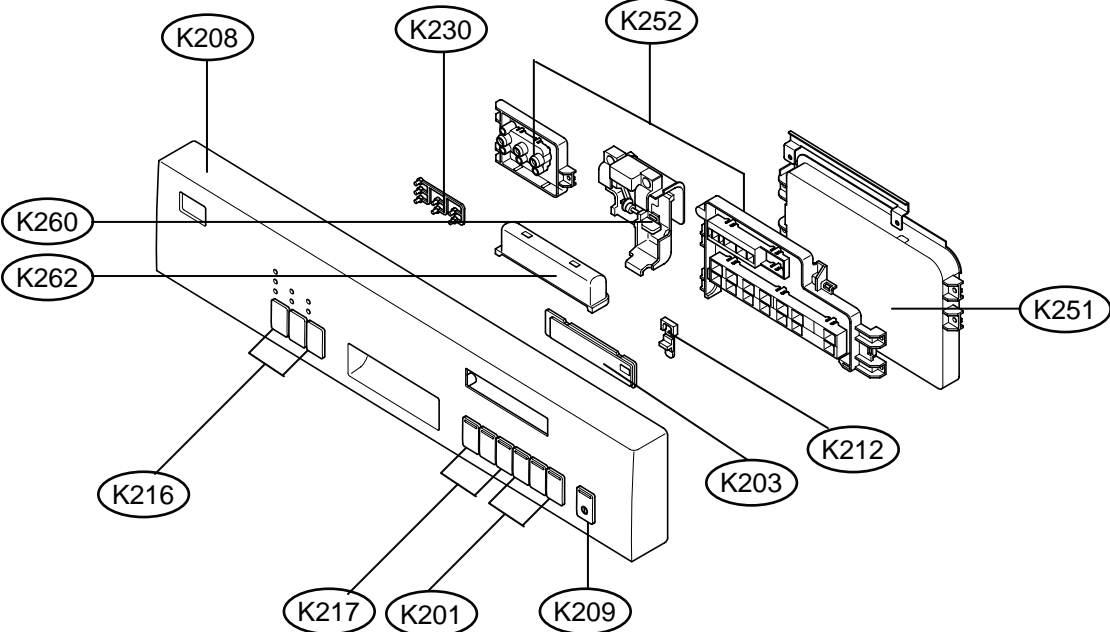
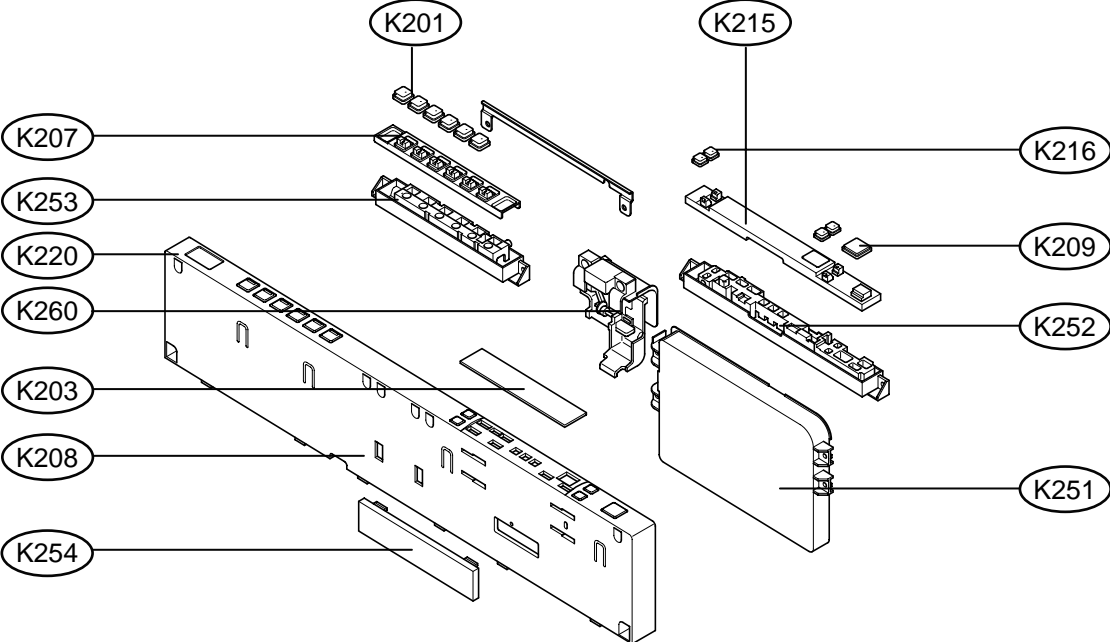

EXPLODED VIEW - PANEL ASSEMBLY (LDF6810 Series)

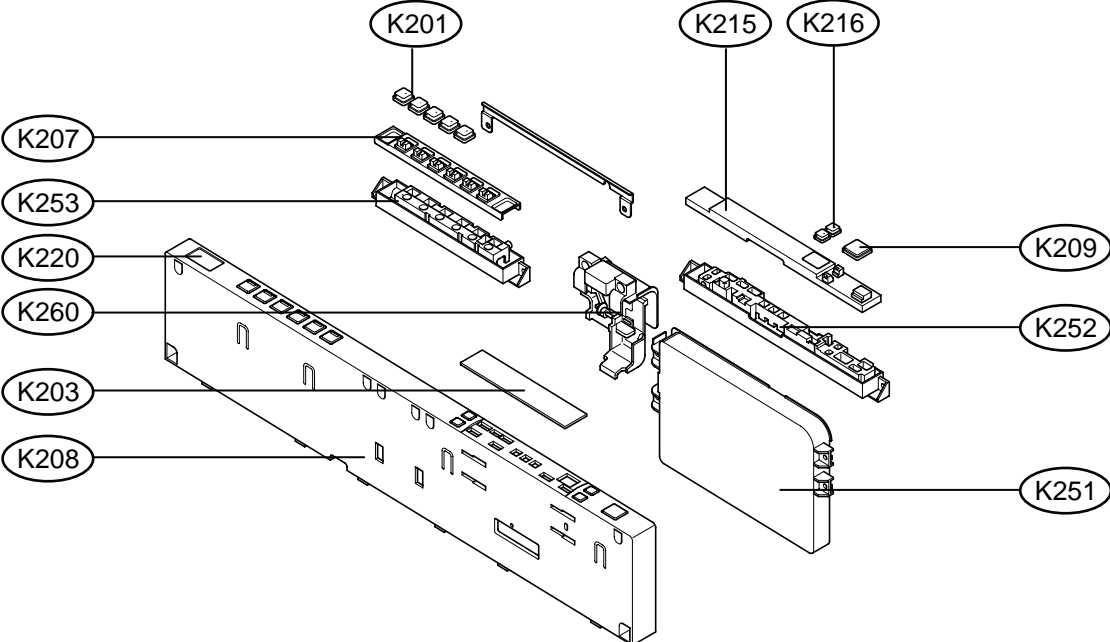

EXPLODED VIEW - DOOR ASSEMBLY

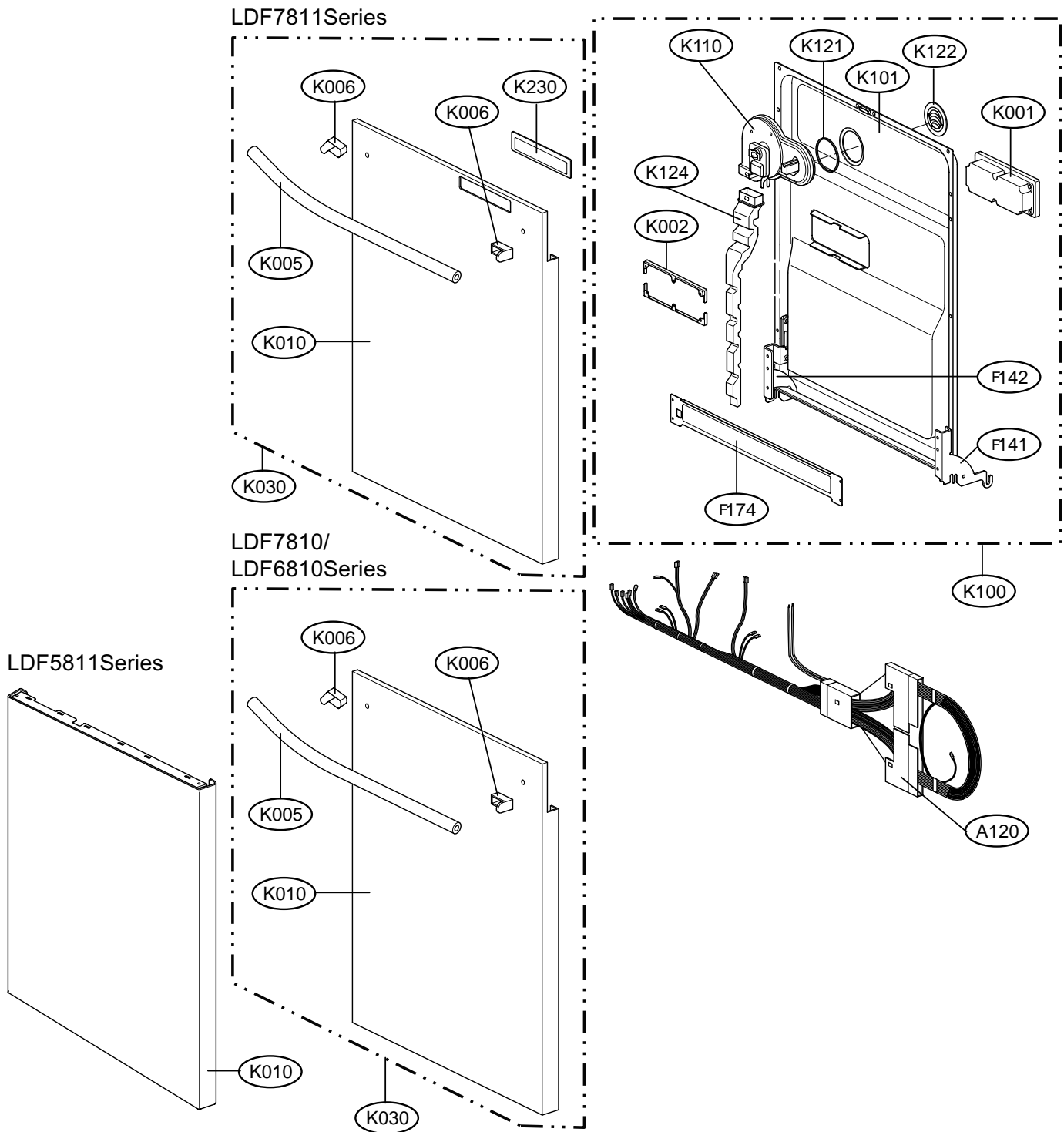

EXPLODED VIEW - SUMP ASSEMBLY

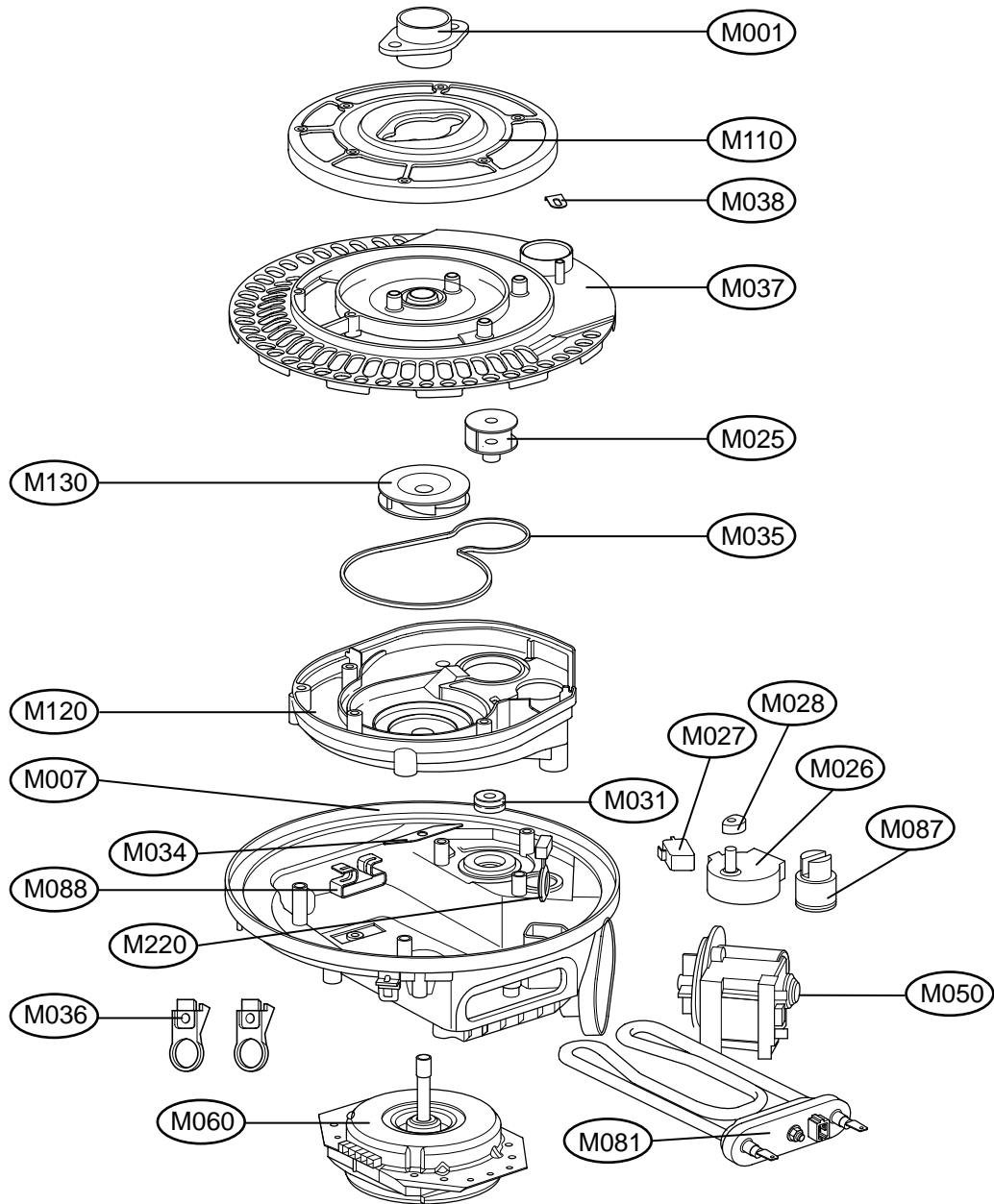

11. REPLACEMENT PART LIST

CAUTION : BEFORE REPLACING ANY OF THESE COMPONENTS.
READ CAREFULLY THE SAFETY PRECAUTIONS IN THIS MANUAL

■ **NOTE :** S(SAFETY PARTS), AL(ALTERNATIVE PARTS)

LG MODEL: LD-6100WB/BB/TB			Run Date : 2005-01-30	
YOUR MODEL: LDF7811WW/BB/ST			SPECIFICATION: 120V 60Hz	
LOC	DESC	PART No.	COMMENTS	QTY
*001	MANUAL ASSEMBLY, OWNER'S	3829DD3002B		1
*002	BOX, CARTON	3890DZ3015A		1
*003	MANUAL, SERVICE	3828ED3001X		1
*005	ACCESSORY ASSEMBLY	5001DD4001A		1
A003	FELT	4766DD2004A	LOWER FELT	1
A005	BRACKET, TOP	4810DD4002B		4
A006	SUPPORTER, HOLDER	4980ED2015A		1
A007	SUPPORTER, HOLDER	4980ED2014A		1
A008	SUPPORTER, HOLDER	4980ED2018A		1
A010	CABINET	WB	3090ED1001A	1
		BB	3090ED1001B	1
		ST	3090ED1001C	1
A020	CABINET	WB	3090ED1002A	1
		BB	3090ED1002B	1
		ST	3090ED1002C	1
A040	COVER ASSEMBLY, LOWER	WB	3551DD2001A	1
		BB	3551DD2001B	1
		ST	3551DD2001C	1
A050	NOZZLE ASSEMBLY	5249DD1002A	LOWER NOZZLE	1
A060	NOZZLE ASSEMBLY	5249DD1001A	UPPER NOZZLE	1
A070	GUIDE ASSEMBLY	4974DD9001A		1
A073	WASHER, DRAWING	1WZZDD3001A		1
A074	SHAFT, NOZZLE	4370ED3007A		1
A080	RACK	3750DD2001A	CUP RACK	2
A101	DECO HANDLE	3806DD3004A	STS	1
A102	HANDLE FRONT	3650DD3001A	FRONT	1
A103	HANDLE REAR	3650DD3002A	REAR	1
A110	BASKET ASSEMBLY, SPOON	5005DD1001A		1
A120	HARNES, PWB	6877DD1002A		1
A130	HOSE ASSEMBLY, DRAIN	5215ED3001E		1
A140	RACK ASSEMBLY	3751DD1001A	LOWER RACK	1
A141	RACK	3750ED1004A		1
A142	ROLLER ASSEMBLY	4581DD9002B		8
A144	RACK	3750DD2003A		2
A147	HOLDER	4930DD3006A		3
A148	RACK	3750DD1001A		1
A149	RACK	3750DD1002A		1
A150	RACK ASSEMBLY	3751DD1002A	UPPER RACK	1
A151	RACK	3750ED1005A		1
A155	GUIDE ASSEMBLY	4975ED2005A	RIGHT	1
A156	GUIDE ASSEMBLY	4975ED2004A	LEFT	1
A157	HOLDER	4930DD3003A		4
A158	HOLDER	4930DD3005A		3
A159	RACK	3750DD2002A		2
A160	FILTER ASSEMBLY (CIRC)	6201EC1006A		1

No.	PART NAME		PART No.	SPEC&COLOR	Q'ty
E010	BUSHING		4830ED4001A		2
F001	FRAME ASSEMBLY		3211DD1001A		1
F004	NOZZLE ASSEMBLY		5249DD2001A	TOP NOZZLE	1
F005	SHAFT NOZZLE		4370ED3006A	TOP NOZZLE	1
F011	SPRING, HINGE		4970ED4004A		2
F013	CONNECTOR ASSEMBLY		4933DD3001A		2
F014	HINGE, BRACKET		4810ED4004A		2
F022	SENSOR ASSEMBLY		6501DD2001A		1
F040	GUIDE ASSEMBLY		4975DD1001A		1
F041	HOSE, INLET		5214DD3001A		1
F042	HOSE, CONNECTOR		5214DD3003A		1
F043	HOSE, CONNECTOR		5214DD3002A		1
F045	COVER, PROTECT		3550DD2001A		1
F050	NUT, DRAWING		4020FD3641C		1
F060	GASKET		4986DD3001A		1
F101	PACKING		3920DD3002A		1
F110	RAIL ASSEMBLY		5219DD2002A	MUST CHANGE F117 TOGETHER(REF 24P-13)	1
F117	STOPPER, ROLLER		4620ED3001A		2
F132	PACKING		3920DD3005A	TUB PACKING	1
F143	HINGE ASSEMBLY		4775ED3004A		1
F144	HINGE ASSEMBLY		4775ED3003A		1
F171	LATCH, LOCK		4026DD3001A		1
F174	BRACKET, HINGE		4810DD1001A	DOOR FRAME	1
F191	GUIDE, WATER		4974DD2003A		1
F192	GUIDE, NOZZLE		4974DD3001A		1
F210	RAIL ASSEMBLY		5219DD2001A	MUST CHANGE F117 TOGETHER(REF 24P-13)	1
K001	DISPENSER		4924FD2123E		1
K002	BRACKET ASSEMBLY		4810FD3805A		2
K005	HANDLE	WB	3650ED2006A		1
		BB	3650ED2006B		1
		ST	3650ED2006C		1
K006	DECO, HANDLE	WB	3806ED3008A		2
		BB	3806ED3008B		2
		ST	3806ED3008C		2
K010	COVER FRONT	WB	3550ED0001A		1
		BB	3550ED0001B		1
		ST	3550ED0001C		1
K030	COVER ASSEMBLY, FRONT	WB	3551DD1003A		1
		BB	3551DD1003B		1
		ST	3551DD1003C		1
K100	DOOR LINER ASM		4937DD9001A	DOOR LINER + DAMPING SHEET + GASKET	1
K110	BLOWER ASSEMBLY		5835ED2002A		1
K121	GASKET		4986DD3003A	BLOWER GASKET	1
K122	COVER, BLOWER		3550ED3011A		1
K124	VENT		5232ED2001A		1
K141	DOOR HINGE ASSEMBLY		4775DD2001A		1
K142	DOOR HINGE ASSEMBLY		4775DD2002A		1
K201	BUTTON, CONTROL	WB	5020ED3008C	PROGRAM BUTTON	6
		BB	5020ED3008D		6
		ST	5020ED3008E		6
K203	WINDOW	WB	3790ED3007A	TOP WINDOW	1
		BB	3790ED3007D		1

No.	PART NAME		PART No.	SPEC&COLOR	Q'ty
K203	WINDOW	ST	3790ED3007E		1
K207	COVER, GUIDE		3550ED3012A		1
K208	PANEL, CONTROL	WB	3720ED1005A		1
		BB	3720ED1005B		1
		ST	3720ED1005C		1
K209	BUTTON, POWER SWITCH	WB	5020ED3011A		1
		BB	5020ED3011B		1
		ST	5020ED3011A		1
K215	COVER, GUIDE		3550ED1009A		1
K216	BUTTON, CONTROL	WB	5020ED3012C	OPTION BUTTON	4
		BB	5020ED3012D		4
		ST	3791DD3001E		1
K220	MARK, PET	WB	3846ER1001A		1
		BB	3846ER1001B		1
		ST	3846ER1001A		1
K230	WINDOW	WB	3791DD3001A	FRONT WINDOW	1
		BB	3791DD3001B		1
		ST	3791DD3001B		1
K251	PWB(PCB) ASSEMBLY, MAIN		6871DD1006A		1
K252	PWB(PCB) ASSEMBLY, DISPLAY		6871DD2001A		1
K253	PWB(PCB) ASSEMBLY, DISPLAY		6871DD2002A		1
K254	DISPLAY LED ASSEMBLY		6327DC3001A		1
K260	LATCH, ASSEMBLY		4027ED3002A		1
M001	HOLDER		4930DD3002A		1
M005	GASKET		4986DD3002A	SUMP GASKET	1
M006	SUMP, ASSEMBLY		3485ED1002A		1
M007	SUMP		3485DD1001A	SUMP+SEAL+GREASE	1
M025	VALVE, CHECK		5220DD3001A		1
M026	MOTOR ASSEMBLY, WM		4681ED3001B	VARIO MOTOR	1
M027	SWITCH, MICRO		3W40025C		1
M028	CAM, SWITCH		4430ED3001A		1
M031	PACKING		3920ED4009B	VARIO PACKING	1
M034	BLADE		5832DD4001A		1
M035	SEAL		4036DD3001A		1
M036	HOLDER		4930DD3008A		1
M037	FILTER ASSEMBLY, MESH		5231DD1001A		1
M038	HOLDER		4930DD3012A		1
M050	MOTOR ASSEMBLY, PUMP		4681EA2002D	DRAIN MOTOR	1
M060	MOTOR ASSEMBLY, WM		4681ED1004A		1
M081	HEATER ASSEMBLY		5301DD1001A		1
M086	MICRO S/W		3W40025P		2
M087	SENSOR ASSEMBLY		6501ED2002D	SOIL SENSOR	1
M088	PROTECTOR (MECH)		3740ED3003A		1
M090	FLOAT ASSEMBLY		4769DD2001A		1
M110	FILTER ASSEMBLY, MESH		5231ED1001A		1
M120	CASE ASSEMBLY		3111DD1001A		1
M130	IMPELLER ASSEMBLY		5911ED3003A		1
M210	VALVE ASSEMBLY, INLET		5221DD1001A		1
M220	VALVE, CHECK		5220ED4004A		1
M260	BASE, CABINET		3040ED1003A		1
M261	COVER ASSEMBLY, BASE		3551DD1002A		1
M262	CASE		3110DD3002A		1
M270	LEG		4778ED3001A		1

**CAUTION : BEFORE REPLACING ANY OF THESE COMPONENTS.
READ CAREFULLY THE SAFETY PRECAUTIONS IN THIS MANUAL**

NOTE : S(SAFETY PARTS), AL(ALTERNATIVE PARTS)

LG MODEL: LD-6090WB/BB/TB			Run Date : 2005-01-30	
YOUR MODEL: LDS5811WW/BB/ST			SPECIFICATION: 120V 60Hz	
LOC	DESC	PART No.	COMMENTS	QTY
*001	MANUAL ASSEMBLY, OWNER'S	3829DD3002C		1
*002	BOX, CARTON	3890DZ3015A		1
*003	MANUAL, SERVICE	3828ED3001X		1
*005	ACCESSORY ASSEMBLY	5001DD4001A		1
A003	FELT	4766DD2004A	LOWER FELT	1
A005	BRACKET, TOP	4810DD4002B		4
A006	SUPPORTER, HOLDER	4980ED2015A		1
A007	SUPPORTER, HOLDER	4980ED2014A		1
A008	SUPPORTER, HOLDER	4980ED2018A		1
A010	CABINET	WB	3090ED1001A	1
		BB	3090ED1001B	1
		ST	3090ED1001C	1
A020	CABINET	WB	3090ED1002A	1
		BB	3090ED1002B	1
		ST	3090ED1002C	1
A040	COVER ASSEMBLY, LOWER	WB	3551DD2001A	1
		BB	3551DD2001B	1
		ST	3551DD2001C	1
A050	NOZZLE ASSEMBLY	5249DD1002A	LOWER NOZZLE	1
A060	NOZZLE ASSEMBLY	5249DD1001A	UPPER NOZZLE	1
A070	GUIDE ASSEMBLY	4974DD9001A		1
A073	WASHER, DRAWING	1WZZDD3001A		1
A074	SHAFT, NOZZLE	4370ED3007A		1
A080	RACK	3750DD2001A	CUP RACK	2
A101	DECO HANDLE	3806DD3004A	STS	1
A102	HANDLE FRONT	3650DD3001A	FRONT	1
A103	HANDLE REAR	3650DD3002A	REAR	1
A110	BASKET ASSEMBLY, SPOON	5005DD1001A		1
A120	HARNES, PWB	6877DD1002A		1
A130	HOSE ASSEMBLY, DRAIN	5215ED3001E		1
A140	RACK ASSEMBLY	3751DD1001A	LOWER RACK	1
A141	RACK	3750ED1004A		1
A142	ROLLER ASSEMBLY	4581DD9002B		8
A144	RACK	3750DD2003A		2
A147	HOLDER	4930DD3006A		3
A148	RACK	3750DD1001A		1
A149	RACK	3750DD1002A		1
A150	RACK ASSEMBLY	3751DD1002B	UPPER RACK	1
A151	RACK	3750ED1005B		1
A152	ROLLER ASM	4581DD9001A		10
A157	HOLDER	4930DD3003A		4
A158	HOLDER	4930DD3005A		3
A159	RACK	3750DD2002A		2
A160	FILTER ASSEMBLY (CIRC)	6201EC1006A		1
E010	BUSHING	4830ED4001A		2

No.	PART NAME		PART No.	SPEC&COLOR	Q'ty
F001	FRAME ASSEMBLY		3211DD1001A		1
F004	NOZZLE ASSEMBLY		5249DD2001A	TOP NOZZLE	1
F005	SHAFT NOZZLE		4370ED3006A	TOP NOZZLE	1
F011	SPRING, HINGE		4970ED4004A		2
F013	CONNECTOR ASSEMBLY		4933DD3001A		2
F014	HINGE, BRACKET		4810ED4004A		2
F022	SENSOR ASSEMBLY		6510DD2001A		1
F040	GUIDE ASSEMBLY		4975DD1001A		1
F041	HOSE, INLET		5214DD3001A		1
F042	HOSE, CONNECTOR		5214DD3003A		1
F043	HOSE, CONNECTOR		5214DD3002A		1
F045	COVER, PROTECT		3550DD2001A		1
F050	NUT, DRAWING		4020FD3641C		1
F060	GASKET		4986DD3001A		1
F101	PACKING		3920DD3002A		1
F110	RAIL ASSEMBLY		5219DD2002A	MUST CHANGE F117 TOGETHER(REF 24P-13)	1
F117	STOPPER, ROLLER		4620ED3001A		2
F132	PACKING		3920DD3005A	TUB PACKING	1
F143	HINGE ASSEMBLY		4775ED3004A		1
F144	HINGE ASSEMBLY		4775ED3003A		1
F171	LATCH, LOCK		4026DD3001A		1
F174	BRACKET, HINGE		4810DD1001A	DOOR FRAME	1
F191	GUIDE, WATER		4974DD2003A		1
F192	GUIDE, NOZZLE		4974DD3001A		1
F210	RAIL ASSEMBLY		5219DD2001A	MUST CHANGE F117 TOGETHER(REF 24P-13)	1
K001	DISPENSER		4924FD2123E		1
K002	BRACKET ASSEMBLY		4810FD3805A		2
K010	COVER ASSEMBLY, FRONT	WB	3551DD1004A		1
		BB	3551DD1004B		1
		ST	3551DD1004D		1
K100	DOOR LINER ASM		4937DD9001A	DOOR LINER + DAMPING SHEET + GASKET	1
K110	BLOWER ASSEMBLY		5835ED2002A		1
K121	GASKET		4986DD3003A	BLOWER GASKET	1
K122	COVER, BLOWER		3550ED3011A		1
K124	VENT		5232ED2001A		1
K141	DOOR HINGE ASSEMBLY		4775DD2001A		1
K142	DOOR HINGE ASSEMBLY		4775DD2002A		1
K201	BUTTON, CONTROL	WB	5020DD2001A	PROGRAM BUTTON	1
		BB	5020DD2001B		1
		ST	5020DD2001C		1
K203	WINDOW	WB	3790DD3001A	PROGRESS WINDOW	1
		BB	3790DD3001B		1
		ST	3790DD3001B		1
K208	PANEL, CONTROL	WB	3720DD1001A		1
		BB	3720DD1001B		1
		ST	3720DD1001C		1
K209	BUTTON, POWER SWITCH	WB	5020DD2004A		1
		BB	5020DD2004B		1
		ST	5020DD2004C		1

No.	PART NAME	PART No.	SPEC&COLOR	Q'ty
K212	BUTTON, CONTROL	5020DD3001A	DELAY START	1
K216	BUTTON, CONTROL	WB	5020DD2003A	OPTION BUTTON
		BB	5020DD2003B	
		ST	5020DD2003C	
K217	BUTTON, CONTROL	WB	5020DD2002A	PROGRAM BUTTON
		BB	5020DD2002B	
		ST	5020DD2002C	
K220	MARK, PET	WB	3846ER1001A	1
		BB	3846ER1001B	1
		ST	3846ER1001A	1
K230	WINDOW	3790DD3002A	OPTION WINDOW	1
K251	PWB(PCB) ASSEMBLY, MAIN	6871DD1006B		1
K252	PWB(PCB) ASSEMBLY, DISPLAY	6871DD2003A		1
K260	LATCH, ASSEMBLY	4027ED3002A		1
K262	HANDLE	WB	3650DD2005A	1
		BB	3650DD2005B	1
		ST	3650DD2005C	1
M001	HOLDER	4930DD3002A		1
M005	GASKET	4986DD3002A	SUMP GASKET	1
M006	SUMP, ASSEMBLY	3485ED1002A		1
M007	SUMP	3485DD1001A	SUMP+SEAL+GREASE	1
M025	VALVE, CHECK	5220DD3001A		1
M026	MOTOR ASSEMBLY, WM	4681ED3001B	VARIO MOTOR	1
M027	SWITCH, MICRO	3W40025C		1
M028	CAM, SWITCH	4430ED3001A		1
M031	PACKING	3920ED4009B	VARIO PACKING	1
M034	BLADE	5832DD4001A		1
M035	SEAL	4036DD3001A		1
M036	HOLDER	4930DD3008A		1
M037	FILTER ASSEMBLY, MESH	5231DD1001A		1
M038	HOLDER	4930DD3012A		1
M050	MOTOR ASSEMBLY, PUMP	4681EA2002D	DRAIN MOTOR	1
M060	MOTOR ASSEMBLY, WM	4681ED1004A		1
M081	HEATER ASSEMBLY	5301DD1001A		1
M086	MICRO S/W	3W40025P		1
M087	SENSOR ASSEMBLY	6501ED2002D	SOIL SENSOR	1
M088	PROTECTOR (MECH)	3740ED3003A		1
M090	FLOAT ASSEMBLY	4769DD2001A		1
M110	FILTER ASSEMBLY, MESH	5231ED1001A		1
M120	CASE ASSEMBLY	3111DD1001A		1
M130	IMPELLER ASSEMBLY	5911ED3003A		1
M210	VALVE ASSEMBLY, INLET	5221DD1001A		1
M220	VALVE, CHECK	5220ED4004A		1
M260	BASE, CABINET	3040ED1003A		1
M261	COVER ASSEMBLY, BASE	3551DD1002A		1
M262	CASE	3110DD3002A		1
M270	LEG	4778ED3001A		1

**CAUTION : BEFORE REPLACING ANY OF THESE COMPONENTS.
READ CAREFULLY THE SAFETY PRECAUTIONS IN THIS MANUAL**

NOTE : S(SAFETY PARTS), AL(ALTERNATIVE PARTS)

LG MODEL: LD-6105WB/BB/TB			Run Date : 2005-01-30	
YOUR MODEL: LDF7810WW/BB/ST			SPECIFICATION: 120V 60Hz	
LOC	DESC	PART No.	COMMENTS	QTY
*001	MANUAL ASSEMBLY, OWNER'S	3829DD3002B		1
*002	BOX, CARTON	3890DZ3015A		1
*003	MANUAL, SERVICE	3828ED3001X		1
*005	ACCESSORY ASSEMBLY	5001DD4001A		1
A003	FELT	4766DD2004A	LOWER FELT	1
A005	BRACKET, TOP	4810DD4002B		4
A006	SUPPORTER, HOLDER	4980ED2015A		1
A007	SUPPORTER, HOLDER	4980ED2014A		1
A008	SUPPORTER, HOLDER	4980ED2018A		1
A010	CABINET	WB	3090ED1001A	1
		BB	3090ED1001B	1
		ST	3090ED1001C	1
A020	CABINET	WB	3090ED1002A	1
		BB	3090ED1002B	1
		ST	3090ED1002C	1
A040	COVER ASSEMBLY, LOWER	WB	3551DD2001A	1
		BB	3551DD2001B	1
		ST	3551DD2001C	1
A050	NOZZLE ASSEMBLY	5249DD1002A	LOWER NOZZLE	1
A060	NOZZLE ASSEMBLY	5249DD1001A	UPPER NOZZLE	1
A070	GUIDE ASSEMBLY	4974DD9001A		1
A073	WASHER, DRAWING	1WZZDD3001A		1
A074	SHAFT, NOZZLE	4370ED3007A		1
A080	RACK	3750DD2001A	CUP RACK	2
A101	DECO HANDLE	3806DD3004A	STS	1
A102	HANDLE FRONT	3650DD3001A	FRONT	1
A103	HANDLE REAR	3650DD3002A	REAR	1
A110	BASKET ASSEMBLY, SPOON	5005DD1001A		1
A120	HARNESS, PWB	6877DD1002A		1
A130	HOSE ASSEMBLY, DRAIN	5215ED3001E		1
A140	RACK ASSEMBLY	3751DD1001A	LOWER RACK	1
A141	RACK	3750ED1004A		1
A142	ROLLER ASSEMBLY	4581DD9002B		8
A144	RACK	3750DD2003A		2
A147	HOLDER	4930DD3006A		3
A148	RACK	3750DD1001A		1
A149	RACK	3750DD1002A		1
A150	RACK ASSEMBLY	3751DD1002A	UPPER RACK	1
A151	RACK	3750ED1005A		1
A155	GUIDE ASSEMBLY	4975ED2005A	RIGHT	1
A156	GUIDE ASSEMBLY	4975ED2004A	LEFT	1
A157	HOLDER	4930DD3003A		4
A158	HOLDER	4930DD3005A		3
A159	RACK	3750DD2002A		2
A160	FILTER ASSEMBLY (CIRC)	6201EC1006A		1

No.	PART NAME		PART No.	SPEC&COLOR	Q'ty
E010	BUSHING		4830ED4001A		2
F001	FRAME ASSEMBLY		3211DD1001A		1
F004	NOZZLE ASSEMBLY		5249DD2001A	TOP NOZZLE	1
F005	SHAFT NOZZLE		4370ED3006A	TOP NOZZLE	1
F011	SPRING, HINGE		4970ED4004A		2
F013	CONNECTOR ASSEMBLY		4933DD3001A		2
F014	HINGE, BRACKET		4810ED4004A		2
F022	SENSOR ASSEMBLY		6501DD2001A		1
F040	GUIDE ASSEMBLY		4975DD1001A		1
F041	HOSE, INLET		5214DD3001A		1
F042	HOSE, CONNECTOR		5214DD3003A		1
F043	HOSE, CONNECTOR		5214DD3002A		1
F045	COVER, PROTECT		3550DD2001A		1
F050	NUT, DRAWING		4020FD3641C		1
F060	GASKET		4986DD3001A		1
F101	PACKING		3920DD3002A		1
F110	RAIL ASSEMBLY		5219DD2002A	MUST CHANGE F117 TOGETHER(REF 24P-13)	1
F013	CONNECTOR ASSEMBLY		4933DD3001A		2
F117	STOPPER, ROLLER		4620ED3001A		2
F132	PACKING		3920DD3005A	TUB PACKING	1
F143	HINGE ASSEMBLY		4775ED3004A		1
F144	HINGE ASSEMBLY		4775ED3003A		1
F171	LATCH, LOCK		4026DD3001A		1
F174	BRACKET, HINGE		4810DD1001A	DOOR FRAME	1
F191	GUIDE, WATER		4974DD2003A		1
F192	GUIDE, NOZZLE		4974DD3001A		1
F210	RAIL ASSEMBLY		5219DD2001A	MUST CHANGE F117 TOGETHER(REF 24P-13)	1
K001	DISPENSER		4924FD2123E		1
K002	BRACKET ASSEMBLY		4810FD3805A		2
K005	HANDLE	WB	3650ED2006A/D		1
		BB	3650ED2006B		1
		ST	3650ED2006C		1
K006	DECO, HANDLE	WB	3806ED3008A		1
		BB	3806ED3008B		2
		ST	3806ED3008C		2
K010	COVER FRONT	WB	3550ED0001E		1
		BB	3551ED0001F		1
		ST	3550ED0001G		1
K030	COVER ASSEMBLY, FRONT	WB	3551DD1001E/H		1
		BB	3551DD1003F		1
		ST	3551DD1003G		1
K100	DOOR LINER ASM		4937DD9001A	DOOR LINER + DAMPING SHEET + GASKET	1
K110	BLOWER ASSEMBLY		5835ED2002A		1
K121	GASKET		4986DD3003A	BLOWER GASKET	1
K122	COVER, BLOWER		3550ED3011A		1
K124	VENT		5232ED2001A		1
K141	DOOR HINGE ASSEMBLY		4775DD2001A		1
K142	DOOR HINGE ASSEMBLY		4775DD2002A		1
K201	BUTTON, CONTROL	WB	5028ED3008C	PROGRAM BUTTON	1
		BB	5020ED3008D		6
		ST	5020ED3008E		6

No.	PART NAME	PART No.	SPEC&COLOR	Q'ty
K203	WINDOW	WB	3790ED3007D	1
		BB	3790ED3007D	1
		ST	3790ED3007E	1
K207	COVER, GUIDE	3550ED3012A		1
K208	PANEL, CONTROL	WB	3720ED1005A	1
		BB	3720ED1005B	1
		ST	3720ED1005C	1
K209	BUTTON, POWER SWITCH	WB	5020ED3011A	1
		BB	5020ED3011B	1
		ST	5020ED3011A	1
K215	COVER, GUIDE	3550ED1009A		1
K216	BUTTON, CONTROL	WB	5020ED3012C	1
		BB	5020ED3012D	4
		ST	5020ED3012E	4
K220	MARK, PET	WB	3846ER1001A	1
		BB	3846ER1001B	1
		ST	3846ER1001A	1
K251	PWB(PCB) ASSEMBLY, MAIN	6871DD1006A		1
K252	PWB(PCB) ASSEMBLY, DISPLAY	6871DD2001A		1
K253	PWB(PCB) ASSEMBLY, DISPLAY	6871DD2002A		1
K260	LATCH, ASSEMBLY	4027ED3002A		1
M001	HOLDER	4930DD3002A		1
M005	GASKET	4986DD3002A	SUMP GASKET	1
M006	SUMP, ASSEMBLY	3485ED1002A		1
M007	SUMP	3485DD1001A	SUMP+SEAL+GREASE	1
M025	VALVE, CHECK	5220DD3001A		1
M026	MOTOR ASSEMBLY, WM	4681ED3001B	VARIO MOTOR	1
M027	SWITCH, MICRO	3W40025C		1
M028	CAM, SWITCH	4430ED3001A		1
M031	PACKING	3920ED4009B	VARIO PACKING	1
M034	BLADE	5832DD4001A		1
M035	SEAL	4036DD3001A		1
M036	HOLDER	4930DD3008A		1
M037	FILTER ASSEMBLY, MESH	5231DD1001A		1
M038	HOLDER	4930DD3012A		1
M050	MOTOR ASSEMBLY, PUMP	4681EA2002D	DRAIN MOTOR	1
M060	MOTOR ASSEMBLY, WM	4681ED1004A		1
M081	HEATER ASSEMBLY	5301DD1001A		1
M086	MICRO S/W	3W40025P		1
M087	SENSOR ASSEMBLY	6501ED2002D	SOIL SENSOR	1
M088	PROTECTOR (MECH)	3740ED3003A		1
M090	FLOAT ASSEMBLY	4769DD2001A		1
M110	FILTER ASSEMBLY, MESH	5231ED1001A		1
M120	CASE ASSEMBLY	3111DD1001A		1
M130	IMPELLER ASSEMBLY	5911ED3003A		1
M210	VALVE ASSEMBLY, INLET	5221DD1001A		1
M220	VALVE, CHECK	5220ED4004A		1
M260	BASE, CABINET	3040ED1003A		1
M261	COVER ASSEMBLY, BASE	3551DD1002A		1
M262	CASE	3110DD3002A		1
M270	LEG	4778ED3001A		1

CAUTION : BEFORE REPLACING ANY OF THESE COMPONENTS.

READ CAREFULLY THE SAFETY PRECAUTIONS IN THIS MANUAL

■ **NOTE** : S(SAFETY PARTS), AL(ALTERNATIVE PARTS)

LG MODEL: LD-6300WB/BB/TB		Run_Date : 2005-01-30		
YOUR MODEL: LDF6810WW/BB/ST		SPECIFICATION: 120V 60Hz		
LOC	DESC	PART No.	COMMENTS	QTY
*001	MANUAL ASSEMBLY, OWNER'S	3829DD3005M		1
*002	BOX, CARTON	3890DZ3015A		1
*003	MANUAL, SERVICE	3828ED3001X		1
*005	ACCESSORY ASSEMBLY	5001DD4001A		1
A003	FELT	4766DD2004A	LOWER FELT	1
A005	BRACKET, TOP	4810DD4002B		4
A006	SUPPORTER, HOLDER	4980ED2015A		1
A007	SUPPORTER, HOLDER	4980ED2014A		1
A008	SUPPORTER, HOLDER	4980ED2018A		1
A010	CABINET	WB	3090ED1001A	1
		BB	3090ED1001B	1
		ST	3090ED1001C	1
A020	CABINET	WB	3090ED1002A	1
		BB	3090ED1002B	1
		ST	3090ED1002C	1
A040	COVER ASSEMBLY, LOWER	WB	3551DD2001A	1
		BB	3551DD2001B	1
		ST	3551DD2001C	1
A050	NOZZLE ASSEMBLY	5249DD1002A	LOWER NOZZLE	1
A060	NOZZLE ASSEMBLY	5249DD1001A	UPPER NOZZLE	1
A070	GUIDE ASSEMBLY	4974DD9001A		1
A073	WASHER, DRAWING	1WZZDD3001A		1
A074	SHAFT, NOZZLE	4370ED3007A		1
A080	RACK	3750DD2001A	CUP RACK	2
A101	DECO HANDLE	3806DD3004A	STS	1
A102	HANDLE FRONT	3650DD3001A	FRONT	1
A103	HANDLE REAR	3650DD3002A	REAR	1
A110	BASKET ASSEMBLY, SPOON	5005DD1001A		1
A120	HARNESS, PWB	6877DD1002A		1
A130	HOSE ASSEMBLY, DRAIN	5215ED3001E		1
A140	RACK ASSEMBLY	3751DD1006A	LOWER RACK	1
A141	RACK	3750DD1007A		1
A142	ROLLER ASSEMBLY	4581DD9002B		8
A144	RACK	3750DD2003A		2
A147	HOLDER	4930DD3006A		3
A150	RACK ASSEMBLY	3751DD1005A	UPPER RACK	1
A151	RACK	3751DD1005A		1
A152	ROLLER ASM	4581DD3002A		10
A158	HOLDER	4930DD3005A		3
A160	FILTER ASSEMBLY (CIRC)	6201EC1006A		1
E010	BUSHING	4830ED4001A		2
F001	FRAME ASSEMBLY	3211DD1001A		1
F004	NOZZLE ASSEMBLY	5249DD2001A	TOP NOZZLE	1
F005	SHAFT NOZZLE	4370ED3006A	TOP NOZZLE	1

No.	PART NAME	PART No.	SPEC&COLOR	Q'ty
F011	SPRING, HINGE	4970ED4004A		2
F013	CONNECTOR ASSEMBLY	4933DD3001A		2
F014	HINGE, BRACKET	4810ED4004A		2
F022	SENSOR ASSEMBLY	6501DD2001A		1
F040	GUIDE ASSEMBLY	4975DD1001A		1
F041	HOSE, INLET	5214DD3001A		1
F042	HOSE, CONNECTOR	5214DD3003A		1
F043	HOSE, CONNECTOR	5214DD3002A		1
F045	COVER, PROTECT	3550DD2001A		1
F050	NUT, DRAWING	4020FD3641C		1
F060	GASKET	4986DD3001A		1
F101	PACKING	3920DD3002A		1
F110	RAIL ASSEMBLY	5219DD2002A	MUST CHANGE F117 TOGETHER(REF 24P-13)	1
F013	CONNECTOR ASSEMBLY	4933DD3001A		2
F117	STOPPER, ROLLER	4620ED3001A		2
F132	PACKING	3920DD3005A	TUB PACKING	1
F143	HINGE ASSEMBLY	4775ED3004A		1
F144	HINGE ASSEMBLY	4775ED3003A		1
F171	LATCH, LOCK	4026DD3001A		1
F174	BRACKET, HINGE	3751DD1006A	DOOR FRAME	1
F191	GUIDE, WATER	4974DD2003A		1
F192	GUIDE, NOZZLE	4974DD3001A		1
F210	RAIL ASSEMBLY	5219DD2001A	MUST CHANGE F117 TOGETHER(REF 24P-13)	1
K001	DISPENSER	4924FD2123E		1
K002	BRACKET ASSEMBLY	4810FD3805A		2
K005	HANDLE	WB	3650ED2006A	1
		BB	3650ED2006B	1
		ST	3650ED2006C	1
K006	DECO, HANDLE	WB	3806ED3008A	2
		BB	3806ED3008B	2
		ST	3806ED3008C	2
K010	COVER FRONT	WB	3550ED0001E	1
		BB	3550ED0001F	1
		ST	3550ED0001G	1
K030	COVER ASSEMBLY, FRONT	WB	3551DD1003H	1
		BB	3551DD1003F	1
		ST	3551DD1003G	1
K100	DOOR LINER ASM	4937DD9001A	DOOR LINER + DAMPING SHEET + GASKET	1
K110	BLOWER ASSEMBLY	5835ED2002A		1
K121	GASKET	4986DD3003A	BLOWER GASKET	1
K122	COVER, BLOWER	3550ED3011A		1
K124	VENT	5232ED2001A		1
K141	DOOR HINGE ASSEMBLY	4775DD2001A		1
K142	DOOR HINGE ASSEMBLY	4775DD2002A		1
K201	BUTTON, CONTROL	WB	5020ED3008C	5
		BB	5020ED3008D	5
		ST	5020ED3008R	5
K203	WINDOW	WB	3790ED3007Q	1
		BB	3790ED3007R	1

No.	PART NAME		PART No.	SPEC&COLOR	Q'ty
K203	WINDOW	ST	3790ED3007P		1
K207	COVER, GUIDE		3550ED3012B		1
K208	PANEL, CONTROL	WB	3720ED1005E		1
		BB	3720ED1005F		1
		ST	3720ED1005D		1
K209	BUTTON, POWER SWITCH	WB	5020ED3011A		1
		BB	5020ED3011B		1
		ST	5020ED3011A		1
K215	COVER, GUIDE		3550ED1009B		1
K216	BUTTON, CONTROL	WB	5020ED3012C	OPTION BUTTON	2
		BB	5020ED3012D		2
		ST	5020ED3012E		2
K220	MARK, PET	WB	3846ER1001A		1
		BB	3846ER1001B		1
		ST	3846ER1001A		1
K251	PWB(PCB) ASSEMBLY, MAIN		6871DD1006A		1
K252	PWB(PCB) ASSEMBLY, DISPLAY		6871DD2001A		1
K253	PWB(PCB) ASSEMBLY, DISPLAY		6871DD2002A		1
K260	LATCH, ASSEMBLY		4027ED3002A		1
M001	HOLDER		4930DD3002A		1
M005	GASKET		4986DD3002A	SUMP GASKET	1
M006	SUMP, ASSEMBLY		3485ED1002B		1
M007	SUMP		3485DD1001A	SUMP+SEAL+GREASE	1
M025	VALVE, CHECK		5220DD3001A		1
M026	MOTOR ASSEMBLY, WM		4681ED3001B	VARIO MOTOR	1
M027	SWITCH, MICRO		3W40025C		1
M028	CAM, SWITCH		4430ED3001A		1
M031	PACKING		3920ED4009B	VARIO PACKING	1
M034	BLADE		5832DD4001A		1
M035	SEAL		4036DD3001A		1
M036	HOLDER		4930DD3008A		1
M037	FILTER ASSEMBLY, MESH		5231DD1001A		1
M038	HOLDER		4930DD3012A		1
M050	MOTOR ASSEMBLY, PUMP		4681EA2002D	DRAIN MOTOR	1
M060	MOTOR ASSEMBLY, WM		4681ED1004A		1
M081	HEATER ASSEMBLY		5301DD1001A		1
M086	MICRO S/W		3W40025P		1
M087	SENSOR ASSEMBLY		6501ED2002E	SOIL SENSOR	1
M088	PROTECTOR (MECH)		3740ED3003A		1
M090	FLOAT ASSEMBLY		4769DD2001A		1
M110	FILTER ASSEMBLY, MESH		5231ED1001A		1
M120	CASE ASSEMBLY		3111DD1001A		1
M130	IMPELLER ASSEMBLY		5911ED3003A		1
M210	VALVE ASSEMBLY, INLET		5221DD1001A		1
M220	VALVE, CHECK		5220ED4004A		1
M260	BASE, CABINET		3040ED1003A		1
M261	COVER ASSEMBLY, BASE		3551DD1002A		1
M262	CASE		3110DD3002A		1
M270	LEG		4778ED3001A		1



MEMO



MEMO



LG Electronics Inc.

P/No. : 3828ED3001X